

## System x3630 M4 (E5-2400 v2) Product Guide (withdrawn product)

The System x3630 M4 server offers a cost-effective high-capacity storage solution with exceptional energy-smart design, leadership virtualization, and powerful systems management. It supports the latest Intel Xeon processor E5-2400 v2 product family and high-density memory designs with twelve DDR3 DIMM slots. This 2U server consolidates storage and server into one system, offers easy management, and saves floor space and power consumption, costing less money than traditional enterprise offerings. Designed with redundancy, flexible subsystems, and a wider range of configuration options, the x3630 M4 also offers an innovative Feature on Demand (FoD) design for an easier upgrade path.

*Suggested use:* Collaboration/email applications, light databases, virtualization/cloud, virtual desktops, web serving, and virtual storage.

The following figure shows the System x3630 M4.



Figure 1. The System

x3630 M4

### Did you know?

The System x3630 M4 server is designed to provide exceptional value and flexibility to meet general business or storage-intensive requirements with up to 56 TB of storage space in a dense 2U form factor and 80 PLUS Platinum certified power supplies. The flexible onboard Ethernet solution provides two standard integrated Gigabit Ethernet ports and two additional integrated Gigabit Ethernet ports with an optional software FoD upgrade without needing to buy additional hardware. Comprehensive systems management tools with the next-generation Integrated Management Module II (IMM2) make it easy to deploy, integrate, service, and manage.

## Key features

Backed by Lenovo worldwide service and support, the x3630 M4 is developed, quality-tested, and certified by Lenovo, the leading vendor in technology patents for 20 years running. System x® advancements in scalability, reliability, and performance can help your business innovate and thrive. With more flexible configuration options, energy-efficient components, and robust systems management tools, the x3630 M4 is an innovative design by Lenovo that can deliver business value over the long term.

### Scalability and performance

The x3630 M4 offers numerous features to boost performance, improve scalability, and reduce costs:

- The Intel Xeon processor E5-2400 v2 product family improves productivity by offering affordable dual-socket system performance with up to 10-core processors, up to 25 MB of L3 cache, and one QPI interconnect link of up to 8 GTps.
- Up to two processors, 20 cores, and 40 threads maximize the concurrent execution of multithreaded applications.
- Intelligent and adaptive system performance with Intel Turbo Boost Technology 2.0 allows processor cores to run at maximum speeds during peak workloads by temporarily going beyond processor thermal design power (TDP).
- Intel Hyper-Threading Technology boosts performance for multithreaded applications by enabling simultaneous multithreading within each processor core, up to two threads per core.
- Intel Virtualization Technology integrates hardware-level virtualization hooks that allow operating system vendors to better use the hardware for virtualization workloads.
- Intel Advanced Vector Extensions (AVX) improve floating point performance for compute-intensive technical and scientific applications.
- Up to 384 GB of memory capacity via 12 DIMM slots with 32 GB LRDIMMs.
- Up to 1600 MHz memory speeds with two DIMMs per channel running at 1600 MHz to help maximize system performance.
- The server offers up to four integrated Gigabit Ethernet ports with convenient Feature on Demand upgrade process that does not require the purchasing of an additional hardware.
- The server offers PCI Express 3.0 I/O expansion capabilities that improve the theoretical maximum bandwidth by almost 100% (8 GTps per link using 128b/130b encoding) compared to the previous generation of PCI Express 2.0 (5 GTps per link using 8b/10b encoding).
- With Intel Integrated I/O Technology, the PCI Express (PCIe) controller is integrated into the Intel Xeon processor E5 family, thereby reducing I/O latency and increasing overall system performance.
- Up to fourteen 3.5-inch hot-swap drive bays provide maximum internal storage density of up to 56 TB in a 2U form factor.

### Availability and serviceability

The x3630 M4 provides many features to simplify serviceability and increase system uptime:

- The server offers Chipkill, memory mirroring, and memory rank sparing for redundancy in the event of a non-correctable memory failure to prevent an unplanned outage.
- Tool-less cover removal provides easy access to upgrades and serviceable parts, such as processor, memory, and adapter cards.
- The server offers simple-swap or hot-swap drives supporting affordable software RAID and advanced hardware RAID redundancy for data protection and greater system uptime.

- The server offers up to two redundant hot-swap power supplies and three dual-motor non-hot-swap redundant fans to provide cost-efficient availability for applications.

- The light path diagnostics panel and individual light path LEDs quickly lead the technician to failed (or failing) components. This panel simplifies servicing, speeds up problem resolution, and helps improve system availability.
- Predictive Failure Analysis (PFA) detects when system components (processors, memory, hard disk drives, fans, and power supplies) operate outside of standard thresholds and generates proactive alerts in advance of a possible failure, therefore increasing uptime.
- Solid-state drives (SSDs) offer significantly better reliability than traditional mechanical HDDs for greater uptime.
- The built-in Integrated Management Module II (IMM2) continuously monitors system parameters, triggers alerts, and performs recovery actions in case of failure, to minimize downtime.
- Built-in diagnostics using Dynamic Systems Analysis (DSA) Preboot speeds up troubleshooting tasks to reduce service time.
- Three-year customer replaceable unit and on-site limited warranty, next business day 9x5. Optional service upgrades available.

### **Manageability and security**

Powerful systems management features simplify local and remote management of the x3630 M4:

- The server includes an Integrated Management Module II (IMM2) to monitor server availability and perform remote management.
- An integrated industry-standard Unified Extensible Firmware Interface (UEFI) enables improved setup, configuration, and updates, and simplifies error handling.
- Integrated Trusted Platform Module (TPM) V1.2 support enables advanced cryptographic functionality, such as digital signatures and remote attestation.
- IBM Systems Director is included for proactive systems management. It offers comprehensive systems management tools that help increase uptime, reduce costs, and improve productivity through advanced server management capabilities.
- Industry-standard AES NI support provides faster and stronger encryption.
- Intel Execute Disable Bit functionality can help prevent certain classes of malicious buffer overflow attacks when combined with a supporting operating system.
- Intel Trusted Execution Technology provides enhanced security through hardware-based resistance to malicious software attacks, allowing an application to run in its own isolated space protected from all other software running on a system.

### **Energy efficiency**

The x3630 M4 offers the following energy-efficiency features to save energy, reduce operational costs, increase energy availability, and contribute to a green environment:

- Energy-efficient planar components help lower operational costs.
- 80 PLUS Platinum certified power supplies enable greater energy savings while providing flexibility to meet your business needs.
- The Intel Xeon processor E5-2400 v2 product family offers better performance over the previous generation, while fitting into the same TDP limits.
- Intel Intelligent Power Capability powers individual processor elements on and off as needed, to reduce power draw.
- Low-voltage Intel Xeon processors draw less energy to satisfy the demands of power and thermally constrained data centers and telecommunication environments.
- Low-voltage 1.35 V DDR3 memory RDIMMs consume 19% less energy compared to 1.5 V DDR3 RDIMMs.

- Solid state drives (SSDs) consume as much as 80% less power than traditional spinning HDDs.
- The server uses hexagonal ventilation holes, a part of Calibrated Vectors Cooling™ technology. Hexagonal holes can be grouped more densely than round holes, providing more efficient airflow through the system.
- IBM Systems Director Active Energy Manager™ provides advanced data center power notification and management to help achieve lower heat output and reduced cooling needs.

## Components and connectors

The following figure shows the front of the server with eight 3.5-inch drive bays.

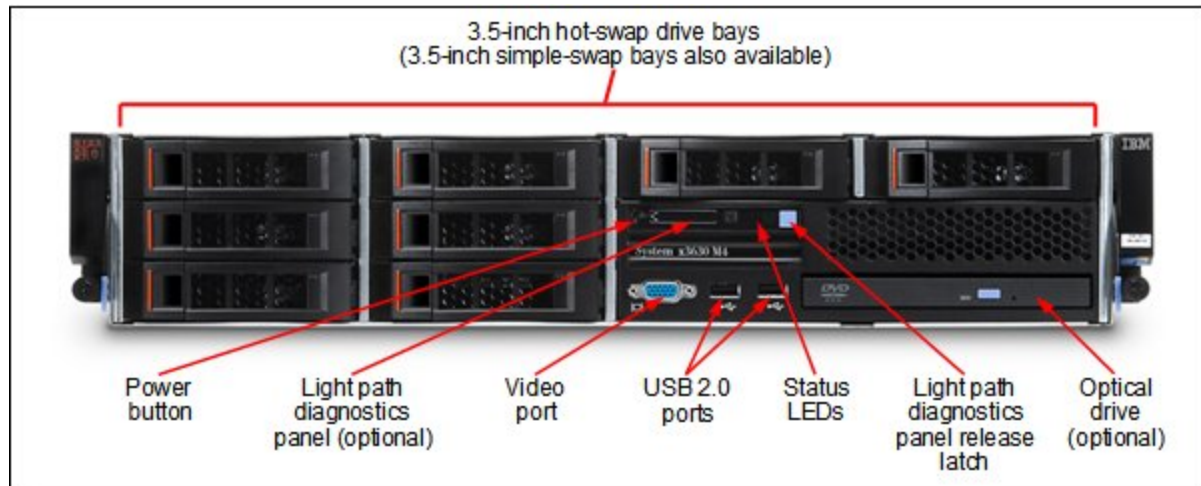

Figure 2. Front view of the System x3630 M4 with eight drive bays

The following figure shows the front of the server with twelve 3.5-inch drive bays.

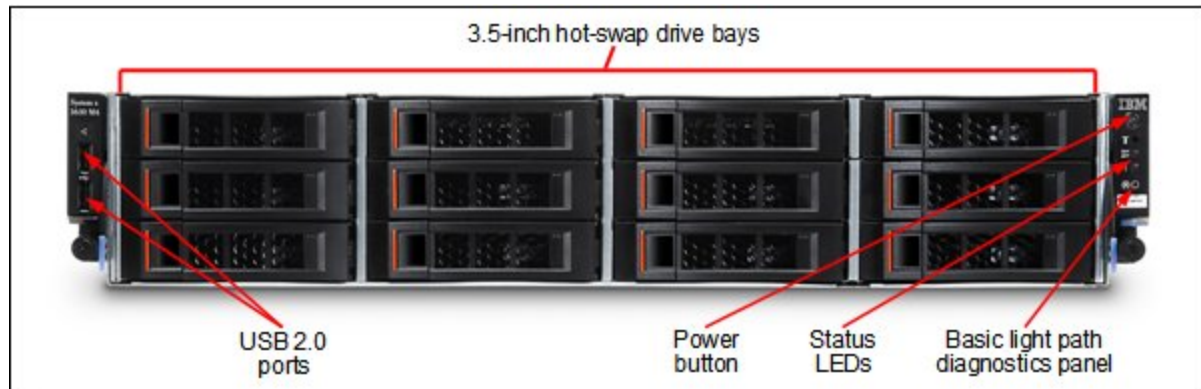

Figure 3. Front view of the System x3630 M4 with twelve drive bays

The following figure shows the rear of the server without the optional rear HDD cage upgrade.

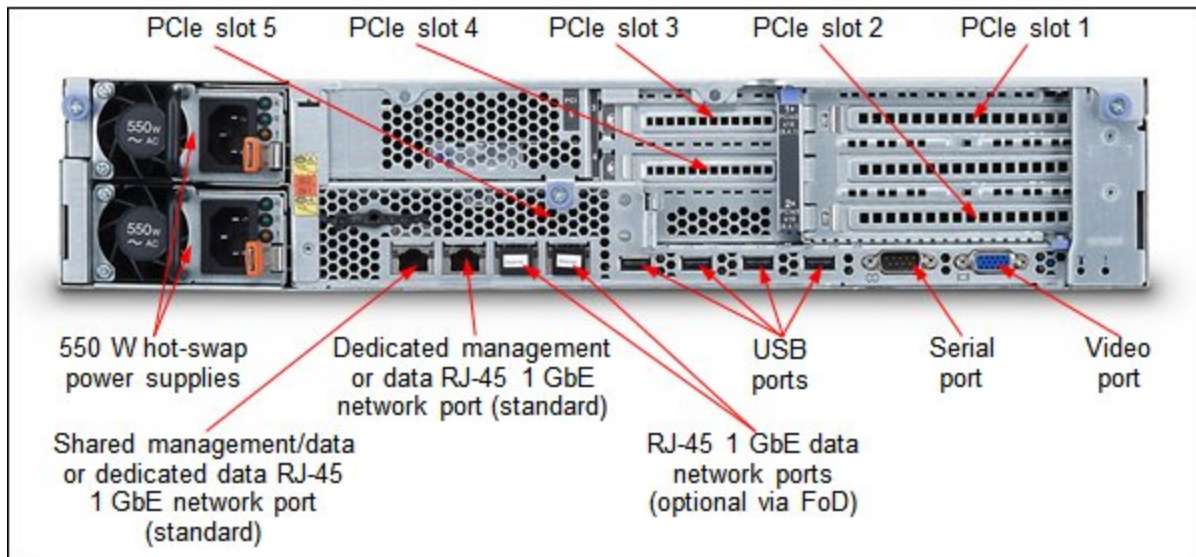

Figure 4. Rear view of the System x3630 M4 without the rear HDD cage

The following shows the rear of the server with the optional rear HDD cage upgrade.

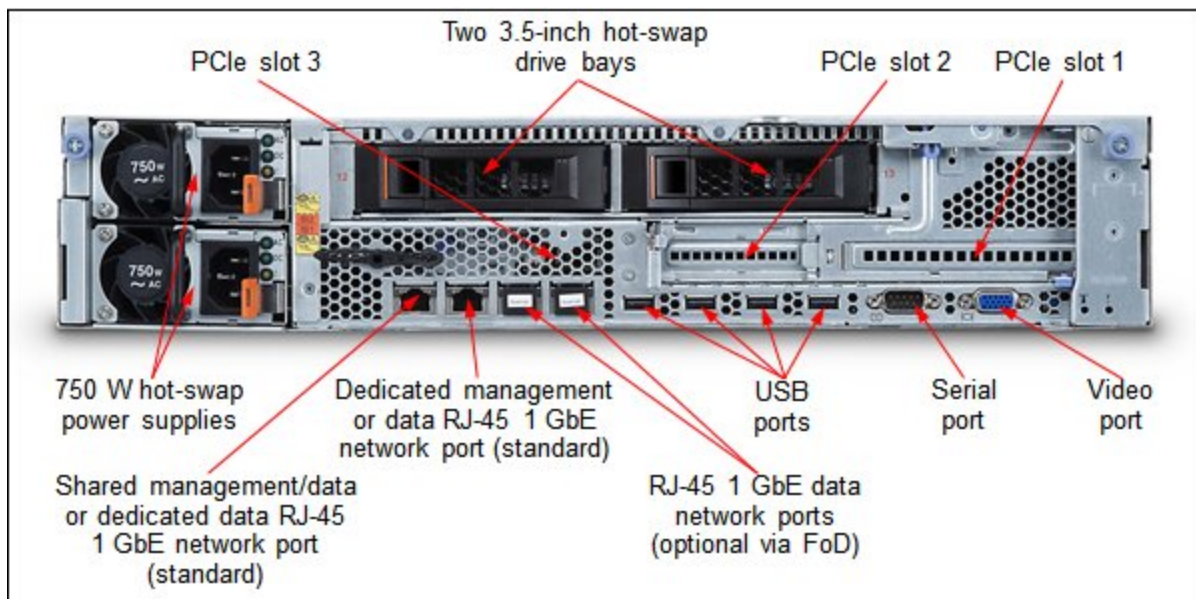

Figure 5. Rear view of the System x3630 M4 with the rear HDD cage

The following figure shows the locations of key components inside the server.

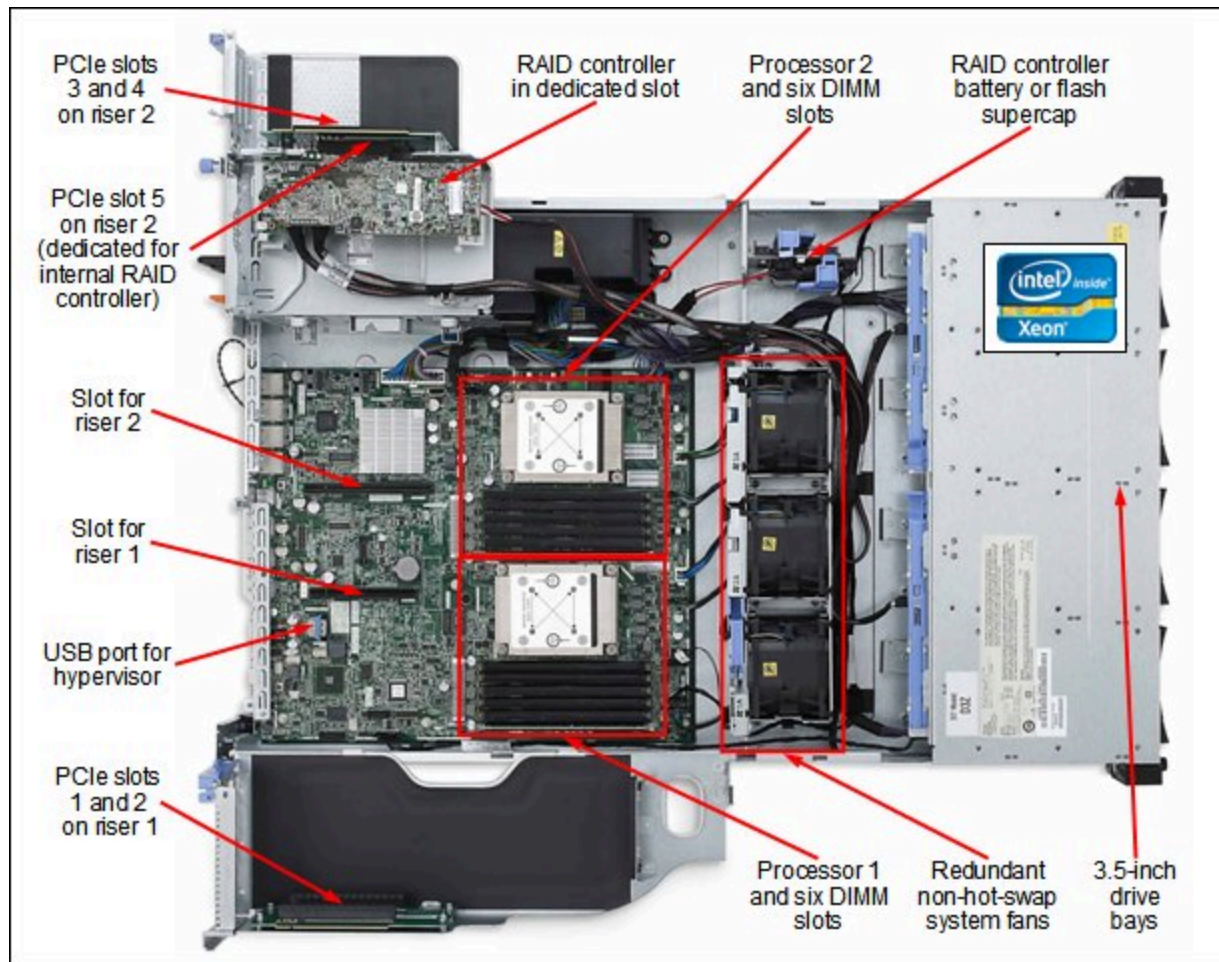

Figure 6. Inside view of the System x3630 M4

## System specifications

The following table lists the system specifications.

Table 1. System specifications

| Components               | Specification   |
|--------------------------|---|
| Machine type             | 7158  |
| Form factor              | 2U rack.  |
| Processor                | Up to two Intel Xeon processor E5-2400 v2 product family processors with 10 cores (up to 2.4 GHz), eight or six cores (up to 2.5 GHz), four cores (up to 2.4 GHz), one QPI link up to 8.0 GTps, up to 1600 MHz memory speed, up to 25 MB L3 cache.  |
| Chipset                  | Intel C600 series.  |
| Memory                   | Up to 12 DIMM sockets (six DIMMs per processor). LRDIMMs, RDIMMs, and UDIMMs are supported, but memory types cannot be intermixed. DIMM speeds are up to 1600 MHz.  |
| Memory maximums          | With LRDIMMs: Up to 384 GB with 12x 32 GB RDIMMs and two processors<br>With RDIMMs: Up to 192 GB with 12x 16 GB RDIMMs and two processors<br>With UDIMMs: Up to 96 GB with 12x 8 GB UDIMMs and two processors   |
| Memory protection        | ECC, Chipkill, memory mirroring, and memory rank sparing.   |
| Disk drive bays          | Up to eight 3.5-inch SATA simple-swap drive bays, up to eight 3.5-inch SAS/SATA hot-swap drive bays, or up to fourteen 3.5-inch SAS/SATA hot-swap drive bays.   |
| Maximum internal storage | Up to 84 TB with 6 TB 3.5-inch NL SAS/SATA HS HDDs, up to 32 TB with 4 TB 3.5-inch SATA SS HDDs, or up to 22.4 TB with 1.6 TB GB 3.5-inch SATA HS SSDs. An intermix of SAS/SATA is supported.   |
| RAID support             | JBOD (Linux only) or RAID 0 and 1 with C105. RAID 0, 1, and 10 with M1115 or M5110. Upgrades to RAID 5 and 50 are available for M1115. Upgrades to RAID 5 and 50 are available for M5110 (zero-cache; 512 MB battery-backed cache; 512 MB, 1 GB, or 2 GB flash-backed cache). Upgrade to RAID 6 or 60 is available for M5110 with caches. |
| Optical drive bays       | One, for models with up to eight 3.5-inch drive bays. Support for optional DVD-ROM or Multiburner.  |
| Tape drive bays          | Optional, for models with up to eight 3.5-inch drive bays. Tape Enablement Kit is required to support the internal tape drive. Support for optional DDS5 or DDS6 USB tape drives is available.  |
| Network interfaces       | Up to four integrated Gigabit Ethernet 1000BASE-T RJ-45 ports with the onboard Intel I350-CM2 controller (two ports enabled, and an additional two ports require the optional software FoD upgrade to enable them).   |
| Ports                    | Two USB 2.0 and one DB-15 video (not available on storage-rich models) port on the front. Four USB 2.0, one DB-15 video, one DB-9 serial, and four RJ-45 GbE network ports on the rear. Two internal USB ports (one for embedded hypervisor, one for internal USB tape drive).  |
| Cooling                  | Calibrated Vectored Cooling with three redundant non-hot-swap fans; each fan has two motors.  |
| Power supply             | Up to two redundant hot-swap 550 W HE AC, 750 W HE AC, or 900 W HE AC power supplies (all AC power supplies are 80 PLUS Platinum certified), or up to two redundant hot-swap 750 W HE DC power supplies.  |
| Hot-swap parts           | Hard drives (hot-swap models), power supplies.  |

| Components                  | Specification  |
|-----------------------------|--|
| I/O expansion slots         | <p>Up to five slots in models with up to 12 drive bays, depending on the riser cards installed. The slots are as follows:</p> <ul style="list-style-type: none"> <li>Slot 1: PCIe 3.0 x16 (x8-wired), optional PCIe 3.0 x16 (x16-wired); full-height, full-length</li> <li>Slot 2: PCIe 3.0 x16 (x8-wired); full-height, half-length (not present if optional x16-wired slot 1 riser is used)</li> <li>Slot 3: PCIe 3.0 x16 (x8-wired), optional PCIe 3.0 x16 (x16-wired); low-profile, half-length (the second processor is required to use this slot)</li> <li>Slot 4: PCIe 3.0 x16 (x8-wired); low-profile, half-length (not present if optional x16-wired slot 3 riser is used, the second processor is required to use this slot)</li> <li>Slot 5: PCIe 3.0 x8 (x4-wired); dedicated slot for ServeRAID adapter; standard on hardware RAID models, optional on software RAID models</li> </ul> <p>Up to three slots in models with 14 drive bays, depending on the riser cards installed. The slots are as follows:</p> <ul style="list-style-type: none"> <li>Slot 1: PCIe 3.0 x8 (x8-wired), optional PCIe 3.0 x16 (x16-wired); full-height, half-length</li> <li>Slot 2: PCIe 3.0 x8 (x8-wired); low-profile, half-length (not present if an optional x16-wired slot 1 riser is used)</li> <li>Slot 3: PCIe 3.0 x8 (x4-wired), optional PCIe 3.0 x8 (x8-wired); dedicated slot for ServeRAID adapter (x8-wired slot requires the second processor, x4-wired slot does not require the second processor)</li> </ul> |
| Systems management          | UEFI, Integrated Management Module II (IMM2), Predictive Failure Analysis, light path diagnostics (basic standard, advanced optional), Automatic Server Restart, IBM Systems Director and IBM Systems Director Active Energy Manager, and ServerGuide. Optional IMM Advanced FoD Upgrade for remote presence (graphics, keyboard and mouse, and virtual media).  |
| Security features           | Power-on password, administrator's password, and Trusted Platform Module (TPM).  |
| Video                       | Matrox G200eR2 with 16 MB memory integrated into the IMM2. Maximum resolution is 1600x1200 at 75 Hz with 16 M colors.  |
| Operating systems supported | Microsoft Windows Server 2012 R2, 2012, 2008 R2, and 2008 (x64), Red Hat Enterprise Linux 5 and 6, SUSE Linux Enterprise Server 11, VMware vSphere (ESXi) 5.0, 5.1, and 5.5.   |
| Limited warranty            | Three-year customer-replaceable unit and on-site limited warranty with 9x5/NBD.  |
| Service and support         | Optional service upgrades (country-specific) are available through Lenovo Services offerings: 4-hour or 2-hour response time, 8 hours fix time, one-year or two-year warranty extension, remote technical support for Lenovo hardware and selected Lenovo and third-party (Microsoft, Linux, VMware) software.   |
| Dimensions                  | Height: 86 mm (3.4 in.), width: 447 mm (17.6 in.), depth: 749 mm (29.5 in.)  |
| Weight                      | Minimum configuration: 16.4 kg (36.2 lb), maximum: 28.2 kg (62.2 lb)   |

The x3630 M4 servers are shipped with the following items:

- Registration flyer
- Statement of Limited Warranty
- Important Notices
- Rack Installation Instructions
- Documentation CD containing *Installation and User's Guide*
- Rail kit (static rails, non-sliding; no cable management arm included)
- One 2.8m, 10A/100-250V, C13 to IEC 320-C14 rack power cable

## Standard models

The following table lists the standard models.

Table 2. Standard models

| Model number*                 | Intel Xeon processors†<br>(two maximum)     | Memory<br>(RDIMMs) | RAID controller         | Drive bays<br>(std / max) | Drives   | Onboard NIC<br>(std / max) | I/O slots<br>(std / max) | Optical drive | Power supply<br>(std / max) |
|-------------------------------|---|--------------------|-------------------------|---------------------------|----------|----------------------------|--------------------------|---------------|-----------------------------|
| Models announced January 2014 |   |                    |                         |                           |          |                            |                          |               |                             |
| 7158A3x                       | 1x E5-2403 v2 4C 1.8GHz<br>10MB 1333MHz 80W | 1x 4GB<br>1600MHz§ | C105                    | 4x 3.5"<br>SS / 4         | Open bay | 2x GbE / 4                 | 2 / 5                    | Optional      | 1x 550 W<br>HS / 2          |
| 7158A5x                       | 1x E5-2403 v2 4C 1.8GHz<br>10MB 1333MHz 80W | 1x 4GB<br>1600MHz§ | C105 8-Pack             | 8x 3.5"<br>HS / 8         | Open bay | 2x GbE / 4                 | 2 / 5                    | Optional      | 1x 550 W<br>HS / 2          |
| 7158B3x                       | 1x E5-2407 v2 4C 2.4GHz<br>10MB 1333MHz 80W | 1x 4GB<br>1600MHz§ | C105 8-Pack             | 8x 3.5"<br>SS / 8         | Open bay | 2x GbE / 4                 | 2 / 5                    | Optional      | 1x 550 W<br>HS / 2          |
| 7158B5x                       | 1x E5-2407 v2 4C 2.4GHz<br>10MB 1333MHz 80W | 1x 4GB<br>1600MHz§ | M1115                   | 12x 3.5"<br>HS / 14       | Open bay | 2x GbE / 4                 | 5 / 5                    | None          | 1x 750 W<br>HS / 2          |
| 7158C3x                       | 1x E5-2420 v2 6C 2.2GHz<br>15MB 1600MHz 80W | 1x 8GB<br>1600MHz  | M5110                   | 8x 3.5"<br>HS / 8         | Open bay | 2x GbE / 4                 | 5 / 5                    | Optional      | 1x 550 W<br>HS / 2          |
| 7158D3x                       | 1x E5-2430 v2 6C 2.5GHz<br>15MB 1600MHz 80W | 1x 8GB<br>1600MHz  | M5110<br>512MB<br>Flash | 12x 3.5"<br>HS / 14       | Open bay | 2x GbE / 4                 | 5 / 5                    | None          | 1x 750 W<br>HS / 2          |
| 7158F5x                       | 1x E5-2440 v2 8C 1.9GHz<br>20MB 1600MHz 95W | 1x 8GB<br>1600MHz  | M5110<br>512MB<br>Flash | 8x 3.5"<br>HS / 8         | Open bay | 2x GbE / 4                 | 5 / 5                    | Optional      | 1x 550 W<br>HS / 2          |
| 7158G3x                       | 1x E5-2450 v2 8C 2.5GHz<br>20MB 1600MHz 95W | 1x 8GB<br>1600MHz  | M5110<br>1GB<br>Flash   | 8x 3.5"<br>HS / 8         | Open bay | 2x GbE / 4                 | 5 / 5                    | Optional      | 1x 750 W<br>HS / 2          |

\* x in the Model number represents a region-specific letter (for example, the EMEA model number is 7158A3G, and the US model number is 7158A3U). Ask a Lenovo representative for specifics.

† Processor detail: Processor quantity and model, cores, core speed, L3 cache, memory speed, TDP.

§ The standard DIMM is rated at 1600 MHz, but operates at up to 1333 MHz to match the processor memory speed. Actual memory speed maximums depend on several factors, as described in "Memory options".

## Express models

The following table lists the express models.

Table 3. Express models

| Model number   | Intel Xeon processors† (two maximum)        | Memory (RDIMMs)    | RAID controller         | Drive bays (std / max) | Drives             | Onboard NIC (std / max) | I/O slots (std / max) | Optical drive   | Power supply (std / max) |
|--|---|--------------------|-------------------------|------------------------|--------------------|-------------------------|-----------------------|-----------------|--------------------------|
| <b>United States</b>   |   |                    |                         |                        |                    |                         |                       |                 |                          |
| 7158EDU  | 1x E5-2403 v2 4C 1.8GHz<br>10MB 1333MHz 80W | 1x 8GB<br>1600MHz§ | M5110                   | 8x 3.5"<br>HS / 8      | Open<br>bay        | 2x GbE / 4              | 5 / 5                 | Multi<br>burner | 1x 550 W<br>HS / 2       |
| 7158EEU  | 1x E5-2420 v2 6C 2.2GHz<br>15MB 1600MHz 80W | 1x 8GB<br>1600MHz  | M5110                   | 8x 3.5"<br>HS / 8      | Open<br>bay        | 2x GbE / 4              | 5 / 5                 | Multi<br>burner | 1x 550 W<br>HS / 2       |
| 7158EFU  | 1x E5-2440 v2 8C 1.9GHz<br>20MB 1600MHz 95W | 1x 8GB<br>1600MHz  | M5110<br>1GB Flash      | 12x 3.5"<br>HS / 14    | Open<br>bay        | 2x GbE / 4              | 5 / 5                 | None            | 2x 750 W<br>HS / 2       |
| <b>Canada</b>  |   |                    |                         |                        |                    |                         |                       |                 |                          |
| 7158EGU  | 2x E5-2440 v2 8C 1.9GHz<br>20MB 1600MHz 95W | 4x 16GB<br>1600MHz | M5110<br>1GB Flash      | 12x 3.5"<br>HS / 14    | Open<br>bay        | 2x GbE / 4              | 5 / 5                 | None            | 2x 750 W<br>HS / 2       |
| <b>Europe</b>  |   |                    |                         |                        |                    |                         |                       |                 |                          |
| 7158EEG  | 1x E5-2420 v2 6C 2.2GHz<br>15MB 1600MHz 80W | 1x 8GB<br>1600MHz  | M5110                   | 8x 3.5"<br>HS / 8      | Open<br>bay        | 2x GbE / 4              | 5 / 5                 | Multi<br>burner | 1x 550 W<br>HS / 2       |
| 7158EHG  | 1x E5-2407 v2 4C 2.4GHz<br>10MB 1333MHz 80W | 1x 8GB<br>1600MHz§ | M5110                   | 8x 3.5"<br>HS / 8      | Open<br>bay        | 2x GbE / 4              | 5 / 5                 | Multi<br>burner | 1x 550 W<br>HS / 2       |
| <b>Central and Eastern Europe (CEE) and Middle East and Africa (MEA)</b> |   |                    |                         |                        |                    |                         |                       |                 |                          |
| 7158EJG  | 1x E5-2407 v2 4C 2.4GHz<br>10MB 1333MHz 80W | 1x 8GB<br>1600MHz§ | M1115                   | 8x 3.5"<br>HS / 8      | Open<br>bay        | 2x GbE / 4              | 5 / 5                 | Multi<br>burner | 1x 550 W<br>HS / 2       |
| <b>Russia/Commonwealth of Independent States (CIS)</b>                   |   |                    |                         |                        |                    |                         |                       |                 |                          |
| 7158EEG  | 1x E5-2420 v2 6C 2.2GHz<br>15MB 1600MHz 80W | 1x 8GB<br>1600MHz  | M5110                   | 8x 3.5"<br>HS / 8      | Open<br>bay        | 2x GbE / 4              | 5 / 5                 | Multi<br>burner | 1x 550 W<br>HS / 2       |
| 7158EHG  | 1x E5-2407 v2 4C 2.4GHz<br>10MB 1333MHz 80W | 1x 8GB<br>1600MHz§ | M5110                   | 8x 3.5"<br>HS / 8      | Open<br>bay        | 2x GbE / 4              | 5 / 5                 | Multi<br>burner | 1x 550 W<br>HS / 2       |
| <b>Latin America (Brazil only)</b>                                       |   |                    |                         |                        |                    |                         |                       |                 |                          |
| 7158EQU  | 1x E5-2420 v2 6C 2.2GHz<br>15MB 1600MHz 80W | 1x 8GB<br>1600MHz  | M1115                   | 8x 3.5"<br>HS / 8      | 2x 1TB<br>7.2K     | 2x GbE / 4              | 5 / 5                 | Multi<br>burner | 1x 550 W<br>HS / 2       |
| 7158ERU  | 1x E5-2420 v2 6C 2.2GHz<br>15MB 1600MHz 80W | 1x 8GB<br>1600MHz  | M1115                   | 8x 3.5"<br>HS / 8      | 2x<br>600GB<br>15K | 2x GbE / 4              | 5 / 5                 | Multi<br>burner | 1x 550 W<br>HS / 2       |
| 7158ETU  | 1x E5-2440 v2 8C 1.9GHz<br>20MB 1600MHz 95W | 1x 8GB<br>1600MHz  | M5110                   | 8x 3.5"<br>HS / 8      | 2x 1TB<br>7.2K     | 2x GbE / 4              | 5 / 5                 | Multi<br>burner | 1x 550 W<br>HS / 2       |
| 7158EUU  | 1x E5-2440 v2 8C 1.9GHz<br>20MB 1600MHz 95W | 1x 8GB<br>1600MHz  | M5110                   | 8x 3.5"<br>HS / 8      | 2x<br>600GB<br>15K | 2x GbE / 4              | 5 / 5                 | Multi<br>burner | 1x 550 W<br>HS / 2       |
| <b>Japan</b>   |   |                    |                         |                        |                    |                         |                       |                 |                          |
| 7158EZJ  | 1x E5-2407 v2 4C 2.4GHz<br>10MB 1333MHz 80W | 1x 4GB<br>1600MHz§ | M5110<br>512MB<br>Flash | 8x 3.5"<br>HS / 8      | Open<br>bay        | 2x GbE / 4              | 5 / 5                 | Optional        | 1x 550 W<br>HS / 2       |

† Processor detail: Processor quantity and model, cores, core speed, L3 cache, memory speed, TDP.

§ The standard DIMM is rated at 1600 MHz, but operates at up to 1333 MHz to match the processor memory speed. Actual memory speed maximums depend on several factors, as described in "Memory options".

## Processor options

The x3630 M4 (E5-2400 v2) supports the processor options listed in the following table. The server supports up to two Intel Xeon processor E5-2400 v2 product family processors. This table shows which server models have each processor standard. If there is no corresponding *where used* model for a particular processor, then this processor is only available through CTO.

Table 4. Processor options

| Part number* | Feature code† | Description  | Standard models where used |
|--------------|---------------|--|----------------------------|
| 00J6381      | A4LM / A4L6   | Intel Xeon Processor E5-2403 v2 4C 1.8GHz 10MB Cache 1333MHz 80W   | A3x, A5x                   |
| 00J6382      | A4LL / A4L5   | Intel Xeon Processor E5-2407 v2 4C 2.4GHz 10MB Cache 1333MHz 80W   | B3x, B5x                   |
| 00Y7437      | A4LQ / A4LE   | Intel Xeon Processor E5-2418L v2 6C 2.0GHz 15MB Cache 1333MHz 50W  | -                          |
| 00J6383      | A4LK / A4L4   | Intel Xeon Processor E5-2420 v2 6C 2.2GHz 15MB Cache 1600MHz 80W   | C3x                        |
| 00Y7438      | A4LR / A4LC   | Intel Xeon Processor E5-2428L v2 8C 1.8GHz 20MB Cache 1600MHz 60W  | -                          |
| 00J6384      | A4LJ / A4L3   | Intel Xeon Processor E5-2430 v2 6C 2.5GHz 15MB Cache 1600MHz 80W   | D3x                        |
| 00J6388      | A4LP / A4L8   | Intel Xeon Processor E5-2430L v2 6C 2.4GHz 15MB Cache 1600MHz 60W  | -                          |
| 00J6385      | A4LH / A4LB   | Intel Xeon Processor E5-2440 v2 8C 1.9GHz 20MB Cache 1600MHz 95W   | F5x                        |
| 00Y7439      | A4LS / A4LD   | Intel Xeon Processor E5-2448L v2 10C 1.8GHz 25MB Cache 1600MHz 70W | -                          |
| 00J6386      | A4LG / A4L2   | Intel Xeon Processor E5-2450 v2 8C 2.5GHz 20MB Cache 1600MHz 95W   | G3x                        |
| 00J6389      | A4LN / A4L7   | Intel Xeon Processor E5-2450L v2 10C 1.7GHz 25MB Cache 1600MHz 60W | -                          |
| 00J6387      | A4LF / A4L0   | Intel Xeon Processor E5-2470 v2 10C 2.4GHz 25MB Cache 1600MHz 95W  | -                          |

\* The option for the second processor includes two additional system fans.

† The first feature code is for the first processor; the second feature code is for the second processor.

\*\* These processors only support single processor configurations and are available only through CTO or special bid.

## Memory options

Lenovo DDR3 memory is compatibility tested and tuned for optimal System x performance and throughput. Lenovo memory specifications are integrated into the light path diagnostics for immediate system performance feedback and optimum system uptime. From a service and support standpoint, Lenovo memory automatically assumes the system warranty, and Lenovo provides service and support worldwide.

The x3630 M4 supports DDR3 memory. The server supports up to six DIMMs when one processor is installed, and up to 12 DIMMs when two processors are installed. Each processor has three memory channels, and there are two DIMMs per channel. The following rules apply when selecting the memory configuration:

- Mixing different types of memory (UDIMMs, RDIMMs, and LRDIMMs) is not supported.
- The maximum number of ranks supported per one channel is eight (with the exception of Load Reduced DIMMs, where more than eight ranks are supported because one quad-rank LRDIMM provides the same electrical load on a memory bus as a single-rank RDIMM).
- The maximum quantity of DIMMs that can be installed in a server depends on the number of processors (six DIMMs with one processor installed, 12 DIMMs with two processors installed)
- All DIMMs in all processor memory channels operate at the same speed, which is determined as the lowest value of:
  - The memory speed supported by the specific processor.
  - The lowest of maximum operating speeds for the selected memory configuration that depends on the rated speed, operating voltage, and quantity of DIMMs per channel, as shown under the "Maximum operating speed" section in Table 5.

The following memory protection technologies are supported:

- ECC
- Chipkill (for x4-based memory DIMMs)
- Memory mirroring
- Memory rank sparing

Chipkill works only in independent channel mode (the default is operational mode) and supports only x4-based memory DIMMs.

If memory mirroring is used, then DIMMs must be installed in pairs (a minimum of one pair per each processor, and a maximum of two pairs per processor), and both DIMMs in a pair must be identical in type and size.

If memory rank sparing is used, then two single-rank or dual-rank DIMMs must be installed per populated channel (the DIMMs do not need to be identical). In rank sparing mode, one rank of a DIMM in each populated channel is reserved as spare memory. The size of a rank varies depending on the DIMMs installed.

Chipkill, memory mirroring, and memory rank sparing modes are mutually exclusive. Only one operational memory mode can be enabled on a server, and it is a system-wide setting.

The following table shows the characteristics of the supported DIMMs. Table cells highlighted with a gray background indicate when the combination of DIMM voltage and the number of DIMMs per channel still allows the DIMMs to operate at a rated speed.

Table 5. Maximum memory speeds

|                      | DIMM type | UDIMM | RDIMM | LRDIMM |
|----------------------|-----------|-------|-------|--------|
| <b>Specification</b> |           |       |       |        |

| Rank                                 | Dual rank                        |          | Single rank                      |          | Dual rank                         |          | Quad rank          |
|--------------------------------------|----------------------------------|----------|----------------------------------|----------|-----------------------------------|----------|--------------------|
| Part number                          | 00D5012 (4 GB)<br>00D5016 (8 GB) |          | 00D5024 (4 GB)<br>00D5036 (8 GB) |          | 00D5044 (8 GB)<br>46W0672 (16 GB) |          | 46W0761<br>(32 GB) |
| Rated speed                          | 1600 MHz                         |          | 1600 MHz                         |          | 1600 MHz                          |          | 1866 MHz           |
| Rated voltage                        | 1.35 V                           |          | 1.35 V                           |          | 1.35 V                            |          | 1.5 V              |
| Operating voltage                    | 1.35 V                           | 1.5 V    | 1.35 V                           | 1.5 V    | 1.35 V                            | 1.5 V    | 1.5 V              |
| Max quantity*                        | 12                               | 12       | 12                               | 12       | 12                                | 12       | 12                 |
| Largest DIMM                         | 8 GB                             | 8 GB     | 8 GB                             | 8 GB     | 16 GB                             | 16 GB    | 32 GB              |
| Max memory capacity                  | 96 GB                            | 96 GB    | 96 GB                            | 96 GB    | 192 GB                            | 192 GB   | 384 GB             |
| Max memory at rated speed            | None**                           | None**   | None**                           | 96 GB    | None**                            | 192 GB   | None**             |
| <b>Maximum operating speed (MHz)</b> |                                  |          |                                  |          |                                   |          |                    |
| 1 DIMM per channel                   | 1333 MHz                         | 1333 MHz | 1333 MHz                         | 1600 MHz | 1333 MHz                          | 1600 MHz | 1333 MHz           |
| 2 DIMMs per channel                  | 1066 MHz                         | 1066 MHz | 1333 MHz                         | 1600 MHz | 1333 MHz                          | 1600 MHz | 1066 MHz           |

\* Maximum quantity supported is shown for two processors installed. When one processor is installed, the maximum quantity supported is a half of what is shown.

\*\* Rated speed is not supported. Memory DIMMs always operate at speeds lower than rated.

The following table lists the memory options available for the x3630 M4 (E5-2400 v2) server.

Table 6. Memory options

| Part number    | Feature code | Description  | Maximum supported | Standard models where used |
|----------------|--------------|--|-------------------|----------------------------|
| <b>UDIMMs</b>  |              |  |                   |                            |
| 00D5012        | A3QB         | 4GB (1x4GB, 2Rx8, 1.35V) PC3L-12800 CL11 ECC DDR3 1600MHz LP UDIMM   | 12 (6 per CPU)    | -                          |
| 00D5016        | A3QC         | 8GB (1x8GB, 2Rx8, 1.35V) PC3L-12800 CL11 ECC DDR3 1600MHz LP UDIMM   | 12 (6 per CPU)    | -                          |
| <b>RDIMMs</b>  |              |  |                   |                            |
| 00D5024        | A3QE         | 4GB (1x4GB, 1Rx4, 1.35V) PC3L-12800 CL11 ECC DDR3 1600MHz LP RDIMM   | 12 (6 per CPU)    | A3x, A5x, B3x, B5x         |
| 00D5036        | A3QH         | 8GB (1x8GB, 1Rx4, 1.35V) PC3L-12800 CL11 ECC DDR3 1600MHz LP RDIMM   | 12 (6 per CPU)    | -                          |
| 00D5044        | A3QK         | 8GB (1x8GB, 2Rx8, 1.35V) PC3L-12800 CL11 ECC DDR3 1600MHz LP RDIMM   | 12 (6 per CPU)    | C3x, D3x, F5x, G3x         |
| 46W0672        | A3QM         | 16GB (1x16GB, 2Rx4, 1.35V) PC3L-12800 CL11 ECC DDR3 1600MHz LP RDIMM | 12 (6 per CPU)    | -                          |
| <b>LRDIMMs</b> |              |  |                   |                            |
| 46W0761        | A47K         | 32GB (1x32GB, 4Rx4, 1.5V) PC3-14900 CL13 ECC DDR3 1866MHz LP LRDIMM  | 12 (6 per CPU)    | -                          |

## Internal storage

The x3630 M4 server supports the following internal storage configurations:

- Four 3.5-inch SATA simple-swap drive bays
- Eight 3.5-inch SATA simple-swap drive bays
- Eight 3.5-inch SAS/SATA hot-swap drive bays
- Twelve 3.5-inch SAS/SATA hot-swap drive bays
- Fourteen 3.5-inch SAS/SATA hot-swap drive bays

In addition, four and eight bay models support the installation of either an internal optical drive or an internal tape drive.

The following figure shows some of these configurations.



Figure 7. Internal drive configurations

Standard models ship with four or eight 3.5-inch SATA simple-swap drive bays or eight 3.5-inch SAS/SATA hot-swap drive bays. Storage-rich models ship with twelve 3.5-inch SAS/SATA hot-swap drive bays, and they can also be upgraded to fourteen 3.5-inch hot-swap drive bay models with the optional rear drive cage assembly. The following table shows the internal storage expansion options that are available.

Table 7. Internal storage expansion options

| Part number | Feature code | Description                                    | Maximum supported | Standard models where used   |
|-------------|--------------|--|-------------------|------------------------------|
| 00Y7548     | A56T         | x3630 M4 Rear Cage Assembly, 2 x 3.5" Hot Swap | 1                 | -                            |
| 00AL388     | A4SF         | x3630 M4 Rear Fan Kit                          | 1                 | -                            |
| 00D9051     | A1ZL         | x3630 M4 ODD Cage assembly                     | 1                 | A3x, A5x, B3x, C3x, F5x, G3x |
| 90Y6370     | A1ZM         | USB Tape Drive Cage assembling kit             | 1                 | -                            |

Option 00Y7548 is used to upgrade standard (see Table 2) or custom (CTO or special bid) models with twelve 3.5-inch hot-swap drive bays to fourteen 3.5-inch hot-swap drive bays. This option must be ordered together with the option 00AL388, x3630 M4 Rear Fan Kit.

Option 00Y7548 contains the drive backplane, drive cage, signal and data cables, and two 1U riser cards: PCIe Riser Card for slot 1 (1 x8 FH/HL + 1 x8 LP Slots) v2 and PCIe Riser Card 2 (1 x4 LP for Slotless RAID) v2. These 1U riser cards replace the standard 2U riser cards used in the models with twelve 3.5-inch hot-swap drive bays, limiting the maximum number of I/O slots to three (for more information, see the "I/O expansion options" section).

Option 00D9051 upgrades any four or eight bay model with an internal optical drive bay (for DVD-ROM or Multiburner). This option includes one USB cable and one power cable. The optical drive is ordered separately. This option is mutually exclusive with 90Y6370, Tape Drive Cage assembly.

**Note:** Option 00D9051, x3630 M4 ODD Cage assembly comes standard with every four or eight bay

standard model listed in Table 2.

Option 90Y6370 upgrades any four or eight bay model with an internal tape drive bay (for DDS5 or DDS6 tape drives). This option includes one USB cable and one power cable. The tape drive is ordered separately. This option is mutually exclusive with 90Y6370, ODD Cage assembly.

## Controllers for internal storage

The following table lists the RAID controllers and HBAs and the additional options used for the internal disk storage of the x3630 M4 server.

Table 8. RAID controllers and HBAs for internal storage

| Part number     | Feature code | Description                                       | Maximum supported | Standard models where used |
|-----------------|--------------|---|-------------------|----------------------------|
| <b>Adapters</b> |              |   |                   |                            |
| None#           | A2VA         | ServeRAID C105                                    | 1                 | A3x, A5x, B3x              |
| 81Y4492         | A1XL         | ServeRAID H1110 SAS/SATA Controller               | 1                 | -                          |
| 81Y4448         | A1MZ         | ServeRAID M1115 SAS/SATA Controller               | 1                 | B5x                        |
| 81Y4481         | A347         | ServeRAID M5110 SAS/SATA Controller               | 1                 | C3x, D3x, F5x, G3x         |
| 46M0912         | 3876         | 6Gb Performance Optimized HBA                     | 1                 | -                          |
| 46C8988         | A3MW         | N2115 SAS/SATA HBA                                | 1                 | -                          |
| <b>Upgrades</b> |              |   |                   |                            |
| 90Y4349§        | A2V7         | 8-pack SATA Enabler                               | 1                 | A5x, B3x                   |
| 81Y4542         | A1X1         | ServeRAID M1100 Series Zero Cache/RAID 5 Upgrade  | 1                 | -                          |
| 81Y4544         | A1X2         | ServeRAID M5100 Series Zero Cache/RAID 5 Upgrade  | 1                 | -                          |
| 81Y4484         | A1J3         | ServeRAID M5100 Series 512MB Cache/RAID 5 Upgrade | 1                 | -                          |
| 81Y4487         | A1J4         | ServeRAID M5100 Series 512MB Flash/RAID 5 Upgrade | 1                 | D3x, F5x                   |
| 81Y4559         | A1WY         | ServeRAID M5100 Series 1GB Flash/RAID 5 Upgrade   | 1                 | G3x                        |
| 47C8670         | A4G6         | ServeRAID M5100 Series 2GB Flash/RAID 5 Upgrade   | 1                 | -                          |
| 81Y4508         | A22E         | ServeRAID M5100 Series Battery Kit                | 1*                | -                          |
| 81Y4546         | A1X3         | ServeRAID M5100 Series RAID 6 Upgrade             | 1†                | -                          |
| 90Y4273         | A2MC         | ServeRAID M5100 Series Performance Accelerator    | 1†                | -                          |
| 90Y4318         | A2MD         | ServeRAID M5100 Series SSD Caching Enabler        | 1†                | -                          |

# The ServeRAID C105 is an onboard software RAID controller.

§ An FoD upgrade for ServeRAID C105 that supports eight SATA HDDs.

\* The ServeRAID M5100 Series Battery Kit (81Y4508) is only supported with ServeRAID M5100 Series 512MB Cache/RAID 5 Upgrade (81Y4484).

† The ServeRAID M5100 Series RAID 6 Upgrade (81Y4546), Performance Accelerator (90Y4273), and Caching Enabler (90Y4318) are Features on Demand (FoD) upgrades that activate the feature on all M5100 Series controllers installed in a server. These FoD upgrades require a RAID 5 Upgrade with caches (81Y4484, 81Y4487, 81Y4559, or 47C8670).

The internal hardware RAID controller is installed into a dedicated PCIe slot (slot 3 for models with 14 drive bays or slot 5 for models with up to 12 drive bays). See Table 13 and Table 14 (PCI riser card options) for more details.

The following table lists drive types and internal drive bay configurations supported by the RAID controllers and HBAs (SAS HDDs include both SAS and NL SAS HDDs, and SATA HDDs include both SATA and NL SATA HDDs).

Table 9. Drive types and internal drive bay configurations supported by the RAID controllers and HBAs

| RAID controller                     | Drive type | 8x 3.5-in. hot-swap | 12x 3.5-in. hot-swap | 14x 3.5-in. hot-swap | 4x 3.5-in. simple-swap | 8x 3.5-in. simple-swap |
|-------------------------------------|------------|---------------------|----------------------|----------------------|------------------------|------------------------|
| ServeRAID C105                      | SAS HDD    | No support          | No support           | No support           | No support             | No support             |
|                                     | SATA HDD   | Yes*                | No support           | No support           | Yes                    | Yes*                   |
|                                     | SATA SSD   | No support          | No support           | No support           | No support             | No support             |
| ServeRAID H1110                     | SAS HDD    | No support          | No support           | No support           | Yes                    | No support             |
|                                     | SATA HDD   | No support          | No support           | No support           | Yes                    | No support             |
|                                     | SATA SSD   | No support          | No support           | No support           | No support             | No support             |
| ServeRAID M1115                     | SAS HDD    | Yes                 | Yes                  | Yes                  | Yes                    | Yes                    |
|                                     | SATA HDD   | Yes                 | Yes                  | Yes                  | Yes                    | Yes                    |
|                                     | SATA SSD   | Yes                 | Yes                  | Yes                  | Yes                    | Yes                    |
| ServeRAID M5110                     | SAS HDD    | Yes                 | Yes                  | Yes                  | Yes                    | Yes                    |
|                                     | SATA HDD   | Yes                 | Yes                  | Yes                  | Yes                    | Yes                    |
|                                     | SATA SSD   | Yes                 | Yes                  | Yes                  | Yes                    | Yes                    |
| 6Gb Performance Optimized HBA N2115 | SAS HDD    | Yes                 | Yes                  | Yes                  | Yes                    | Yes                    |
|                                     | SATA HDD   | Yes                 | Yes                  | Yes                  | Yes                    | Yes                    |
|                                     | SATA SSD   | Yes                 | Yes                  | Yes                  | Yes                    | Yes                    |

\* Requires an FoD upgrade for ServeRAID C105 to support eight SATA HDDs (8-pack SATA Enabler, part number 90Y4349).

The ServeRAID C105 onboard controller has the following specifications:

- Eight internal 3 Gbps SATA ports
- Up to 3 Gbps throughput per port
- Supports up to eight (up to four standard, with an additional four with optional 8-pack enabler, 90Y4349) SATA HDDs (SAS not supported)
- Supports hot-swap and simple-swap drives
- Supports JBOD mode (Linux only) or RAID 0, 1, and 10
- Support for up to eight volumes
- Support for virtual drive sizes greater than 2 TB
- Fixed stripe unit size of 64 KB
- Support for MegaRAID Storage Manager management software

The ServeRAID H1110 adapter has the following specifications:

- Four internal 6 Gbps SAS/SATA ports
- Up to 6 Gbps throughput per port
- One x4 mini-SAS internal connector (SFF-8087)
- Based on the LSI SAS2004 6 Gbps RAID on Chip (ROC) controller
- PCIe 2.0 x4 host interface
- Supports RAID 0, 1, 1E, and 10
- Connects to up to four SAS or SATA drives (SAS expanders are not supported.)

The ServeRAID M1115 SAS/SATA Controller has the following specifications:

- Eight internal 6 Gbps SAS/SATA ports
- Up to 6 Gbps throughput per port
- Two x4 mini-SAS internal connectors (SFF-8087)
- Supports connections to SAS/SATA drives and SAS Expanders
- Supports RAID levels 0, 1, and 10
- Supports RAID levels 5 and 50 with optional M1100 Series RAID 5 upgrades
- PCIe 2.0 x8 host interface
- Based on the LSI SAS2008 6 Gbps ROC controller

The ServeRAID M5110 SAS/SATA Controller has the following specifications:

- Eight internal 6 Gbps SAS/SATA ports
- Up to 6 Gbps throughput per port
- Two x4 mini-SAS internal connectors (SFF-8087)
- Supports connections to SAS/SATA drives and SAS Expanders
- Supports RAID levels 0, 1, and 10
- Supports RAID levels 5 and 50 with optional M5100 Series RAID 5 upgrades
- Supports RAID 6 and 60 with the optional M5100 Series RAID 6 Upgrade
- Supports 512 MB battery-backed cache or 512 MB or 1 GB flash-backed cache
- Support for SSD performance optimization with the optional M5100 Series Performance Accelerator and SSD Caching Enabler
- PCIe 3.0 x8 host interface
- Based on the LSI SAS2208 6 Gbps ROC controller

The 6Gb Performance Optimized HBA has the following specifications:

- Eight internal 6 Gbps SAS/SATA ports
- Up to 6 Gbps throughput per port
- Two x4 mini-SAS internal connectors (SFF-8087)
- Supports connections to SAS/SATA HDDs and SATA SSDs
- Optimized for SSD performance
- No RAID support
- PCIe 2.0 x8 host interface
- Based on the LSI SAS2008 6 Gbps ROC controller

The N2115 SAS/SATA HBA has the following specifications:

- Eight internal 6 Gbps SAS/SATA ports
- Up to 6 Gbps throughput per port
- Two x4 mini-SAS internal connectors (SFF-8087)
- Supports connections to SAS/SATA HDDs and SATA SSDs
- Optimized for SSD performance
- No RAID support
- PCIe 3.0 x8 host interface
- Based on the LSI SAS2308 6 Gbps controller

For more information, see the list of Lenovo Press Product Guides in the RAID adapters category:  
<http://lenovopress.com/servers/options/raid>

## Internal drive options

The following table lists hard drive options for internal disk storage of the x3630 M4 server.

Table 10. Drive options for internal storage

| Part number  | Feature code | Description  | Maximum supported |
|--|--------------|--|-------------------|
| <b>3.5" SAS Hot-Swap HDDs</b>                          |              |  |                   |
| 49Y6092  | A3DV         | 300GB 15K 6Gbps SAS 3.5" G2HS HDD                        | 14                |
| 49Y6102  | A3DX         | 600GB 15K 6Gbps SAS 3.5" G2HS HDD                        | 14                |
| <b>3.5" SAS Hot-Swap Self-encrypting drives (SEDs)</b> |              |  |                   |
| 00W1543  | A4AJ         | 4TB 7.2K 6Gbps NL SAS 3.5" G2HS SED                      | 14                |
| <b>3.5" NL SAS Hot-Swap HDDs</b>                       |              |  |                   |
| 90Y8567  | A26M         | 1TB 7.2K 6Gbps NL SAS 3.5" G2HS HDD                      | 14                |
| 90Y8572  | A2U0         | 2TB 7.2K 6Gbps NL SAS 3.5" G2HS HDD                      | 14                |
| 90Y8577  | A2R2         | 3TB 7.2K 6Gbps NL SAS 3.5" G2HS HDD                      | 14                |
| 49Y6210  | A4AF         | 4TB 7.2K 6Gbps NL SAS 3.5" G2HS HDD                      | 14                |
| 00ML213  | AS78         | 6TB 7.2K 6Gbps NL SAS 3.5" G2HS 512e HDD                 | 14                |
| <b>3.5" NL SATA Hot-Swap HDDs</b>                      |              |  |                   |
| 81Y9786  | A22Y         | 500GB 7.2K 6Gbps NL SATA 3.5" G2HS HDD                   | 14                |
| 81Y9790  | A22P         | 1TB 7.2K 6Gbps NL SATA 3.5" G2HS HDD                     | 14                |
| 81Y9794  | A22T         | 2TB 7.2K 6Gbps NL SATA 3.5" G2HS HDD                     | 14                |
| 00FN113  | A5VD         | 2TB 7.2K 6Gbps NL SATA 3.5" G2HS 512e HDD                | 14                |
| 81Y9798  | A22S         | 3TB 7.2K 6Gbps NL SATA 3.5" G2HS HDD                     | 14                |
| 00FN128  | A5VF         | 3TB 7.2K 6Gbps NL SATA 3.5" G2HS 512e HDD                | 14                |
| 49Y6002  | A3W9         | 4TB 7.2K 6Gbps NL SATA 3.5" G2HS HDD                     | 14                |
| 00FN143  | A5VH         | 4TB 7.2K 6Gbps NL SATA 3.5" G2HS 512e HDD                | 14                |
| 00FN173  | A5VM         | 6TB 7.2K 6Gbps NL SATA 3.5" G2HS 512e HDD                | 14                |
| <b>3.5" NL SATA Simple-Swap HDDs</b>                   |              |  |                   |
| 81Y9802  | A22U         | 500GB 7.2K 6Gbps NL SATA 3.5" G2SS HDD                   | 8                 |
| 81Y9806  | A22X         | 1TB 7.2K 6Gbps NL SATA 3.5" G2SS HDD                     | 8                 |
| 81Y9810  | A22W         | 2TB 7.2K 6Gbps NL SATA 3.5" G2SS HDD                     | 8                 |
| 00FN118  | A5VE         | 2TB 7.2K 6Gbps NL SATA 3.5" G2SS 512e HDD                | 8                 |
| 00FN148  | A5VJ         | 4TB 7.2K 6Gbps NL SATA 3.5" G2SS 512e HDD                | 8                 |
| <b>3.5" SAS Hot-Swap SSDs - Enterprise</b>             |              |  |                   |
| 00W1311  | A4N8         | 400GB SAS 3.5" MLC HS Enterprise SSD                     | 14                |
| 00W1316  | A4N9         | 800GB SAS 3.5" MLC HS Enterprise SSD                     | 14                |
| <b>3.5" SATA Hot-Swap SSDs - Enterprise</b>            |              |  |                   |
| 00AJ485  | A56H         | S3700 400GB SATA 3.5" MLC HS Enterprise SSD for System x | 14                |
| 00AJ490  | A56J         | S3700 800GB SATA 3.5" MLC HS Enterprise SSD for System x | 14                |
| <b>3.5" SATA Hot-Swap SSDs - Enterprise Value</b>      |              |  |                   |
| 00AJ435  | A57F         | 120GB SATA 3.5" MLC HS Enterprise Value SSD              | 14                |
| 00AJ440  | A57G         | 240GB SATA 3.5" MLC HS Enterprise Value SSD              | 14                |

| Part number                            | Feature code | Description                                       | Maximum supported |
|--|--------------|---|-------------------|
| 00AJ445                                | A57H         | 480GB SATA 3.5" MLC HS Enterprise Value SSD       | 14                |
| 00AJ450                                | A57J         | 800GB SATA 3.5" MLC HS Enterprise Value SSD       | 14                |
| 00AJ460                                | A56C         | S3500 120GB SATA 3.5" MLC HS Enterprise Value SSD | 14                |
| 00AJ465                                | A56D         | S3500 240GB SATA 3.5" MLC HS Enterprise Value SSS | 14                |
| 00AJ470                                | A56E         | S3500 480GB SATA 3.5" MLC HS Enterprise Value SSD | 14                |
| 00AJ475                                | A56F         | S3500 800GB SATA 3.5" MLC HS Enterprise Value SSD | 14                |
| 00FN288                                | A5U7         | S3500 1.6TB SATA 3.5" MLC HS Enterprise Value SSD | 14                |
| <b>3.5" SATA Hot-Swap SSDs - Entry</b> |              |   |                   |
| 00FN352                                | AS0K         | 240GB SATA 3.5" MLC HS Entry SSD                  | 14                |
| 00FN357                                | AS0L         | 480GB SATA 3.5" MLC HS Entry SSD                  | 14                |
| 00FN362                                | AS0M         | 960GB SATA 3.5" MLC HS Entry SSD                  | 14                |

## Internal backup units

The server supports the internal backup options listed in the following table. The USB Tape Drive Cage assembling kit, part number 90Y6370, is required to support these tapes internally. The internal tape drive is connected to the dedicated internal USB port on a system board.

Table 11. Internal tape drives

| Part number | Feature code | Description                        | Maximum supported |
|-------------|--------------|------------------------------------|-------------------|
| 90Y6370     | A1ZM*        | USB Tape Drive Cage assembling kit | 1                 |
| 46C5399     | 5711*        | DDS Generation 5 USB Tape Drive    | 1                 |
| 39M5636     | 5395*        | DDS Generation 6 USB Tape Drive    | 1                 |

\* No longer available via CTO

## Optical drives

The server supports the optical drive options listed in the following table. The installation of optical drive may require x3630 M4 ODD Cage assembly, part number 00D9051. Standard models of x3630 M4 with four or eight HDDs ship with the ODD Cage assembly installed. Server models with twelve 3.5-inch HDDs do not support an internal optical drive.

Table 12. Optical drives

| Part number | Feature code | Description                          | Maximum supported | Standard models where used |
|-------------|--------------|--------------------------------------|-------------------|----------------------------|
| 46M0901     | 4161         | UltraSlim Enhanced SATA DVD-ROM      | 1                 | -                          |
| 46M0902     | 4163         | UltraSlim Enhanced SATA Multi-Burner | 1                 | -                          |

UltraSlim Enhanced SATA DVD-ROM (part number 46M0901) supports the following media and speeds for reading:

- CD-ROM 24X
- CD-R 24X
- CD-RW 24X
- DVD-ROM (4.7 GB) 8X
- DVD-ROM (dual layer, 8.5 GB) 8X
- DVD-R (4.7 GB) 8X
- DVD-R (dual layer, 8.5 GB) 8X
- DVD+R (4.7 GB) 8X
- DVD+R (dual layer, 8.5 GB) 8X
- DVD-RW (4.7 GB) 8X
- DVD+RW (4.7 GB) 8X
- DVD-RAM (4.7 GB) 5X

UltraSlim Enhanced SATA Multi-Burner (46M0902) supports the same media and speeds for reading as DVD-ROM (46M0901). This drive also supports the following media and speeds for writing:

- CD-R 24X
- CD-RW 24X
- DVD-R (4.7 GB) 8X
- DVD-R (dual layer, 8.5 GB) 6X
- DVD+R (4.7 GB) 8X
- DVD+R (dual layer, 8.5 GB) 6X
- DVD-RW (4.7 GB) 6X
- DVD+RW (4.7 GB) 8X
- DVD-RAM (4.7 GB) 5X

## I/O expansion options

The server supports up to five PCIe slots with different riser cards installed into two riser sockets on the system planar (one riser socket supports the installation of one riser card). There are two types of riser cards: 2U risers and 1U risers. 2U risers are used in x3630 M4 models that do not have the rear HDD cage assembly (see Figure 4). 1U risers are used in models with the rear HDD cage assembly installed (see Figure 5). See Figure 4 and Figure 5 for slot locations and numbering.

**Note:** You cannot use 1U risers in models without the rear HDD cage. You cannot use 2U risers in models with the rear HDD cage assembly installed.

The slot form factors with 2U risers (models without the rear HDD cage assembly) are as follows:

- Slot 1: PCIe 3.0 x16 (x8-wired), optional PCIe 3.0 x16 (x16-wired); full-height, full-length
- Slot 2: PCIe 3.0 x16 (x8-wired); full-height, half-length (not present if optional x16-wired slot 1 riser is used)
- Slot 3: PCIe 3.0 x16 (x8-wired), optional PCIe 3.0 x16 (x16-wired); low-profile, half-length (the second processor is required to use this slot)
- Slot 4: PCIe 3.0 x16 (x8-wired); low-profile, half-length (not present if optional x16-wired slot 3 riser is used, the second processor is required to use this slot)
- Slot 5: PCIe 3.0 x8 (x4-wired); dedicated slot for ServeRAID adapter; standard on hardware RAID models, optional on software RAID models

**Note:** Standard models with software RAID (ServeRAID C105) ship with one 2U riser supplying slots 1 and 2 (slots 3, 4, and 5 are not present). Standard models with hardware RAID adapters (ServeRAID M1115 or M5110) ship with two 2U risers supplying all five slots. See Table 13 for details.

The slot form factors with 1U risers (models with the rear HDD cage assembly) are as follows:

- Slot 1: PCIe 3.0 x8 (x8-wired), optional PCIe 3.0 x16 (x16-wired); full-height, half-length
- Slot 2: PCIe 3.0 x8 (x8-wired); low-profile, half-length (not present if an optional x16-wired slot 1 riser is used)
- Slot 3: PCIe 3.0 x8 (x4-wired), optional PCIe 3.0 x8 (x8-wired); dedicated slot for ServeRAID adapter (x8-wired slot requires the second processor, x4-wired slot does not require the second processor)

**Note:** The 3.5" Hot Swap Cage Assembly, Rear, 2 x 3.5" option, part number 00Y7548, ships with two 1U risers supplying x8-wired slots 1 and 2 and x4-wired slot 3. See Table 14 for details.

The following two tables lists the I/O riser card options, the 2U riser options and the 1U riser options.

Table 13. 2U I/O riser card options

| Part number                                   | Feature code | Description  | Maximum supported | Standard models where used             |
|---|--------------|--|-------------------|--|
| 2U Riser 1 option (supplies slots 1 and 2)    |              |  |                   |  |
| None*   | A4LY         | PCIe Riser Card 1 (1 x8 FH/FL + 1 x8 FH/HL Slots) v2             | 1                 | A3x, A5x, B3x, B5x, C3x, D3x, F5x, G3x |
| 00Y7550                                       | A4TC         | PCIe Riser Card 1 (1 x16 FH/FL Slot) v2                          | 1                 | -                                      |
| 2U Riser 2 option (supplies slot 3, 4, and 5) |              |  |                   |  |
| 00AL310                                       | A4LZ         | PCIe Riser Card 2 (2 x8 LP Slots + 1 x4 LP for Slotless RAID) v2 | 1                 | B5x, C3x, D3x, F5x, G3x                |
| 00Y7551                                       | A4TD         | PCIe Riser Card 2 (1 x16 LP Slot + 1 x4 LP for Slotless RAID) v2 | 1                 | -                                      |

\* This riser card is installed in all standard models. It can also be used in CTO or special bid models.

Table 14. 1U I/O riser card options

| Part number                                | Feature code | Description  | Maximum supported | Standard models where used |
|--|--------------|--|-------------------|----------------------------|
| 1U Riser 1 option (supplies slots 1 and 2) |              |  |                   |                            |
| None†                                      | A4LU         | PCIe Riser Card for slot 1 (1 x8 FH/HL + 1 x8 LP Slots) v2 | 1                 | -                          |
| None*                                      | A4LV         | PCIe Riser Card 1 (1 x16 FH/HL Slot) for Graphic card v2   | 1                 | -                          |
| 1U Riser 2 option (supplies slot 3)        |              |  |                   |                            |
| None†                                      | A4LW         | PCIe Riser Card 2 (1 x4 LP for Slotless RAID) v2           | 1                 | -                          |
| 00Y7549                                    | A4LX         | PCIe Riser Card 2 (1 x8 LP for Slotless RAID) v2           | 1                 | -                          |

† These riser cards come standard with the 3.5" Hot Swap Cage Assembly, Rear, 2 x 3.5" option (00Y7548).

\* This riser card is only available through CTO or special bid models.

## Network adapters

The x3630 M4 supports up to four integrated Gigabit Ethernet ports (two enabled standard, and two enabled optionally with the FoD upgrade). Integrated NIC has the following features:

- An Intel I350-CM2 chip
- Up to four Gigabit Ethernet ports (two enabled standard, and two enabled optionally with the 90Y9314 FoD upgrade)
- NIC Teaming (load balancing and failover)
- Ethernet Features:
  - 1 Gb Ethernet IEEE 802.3, 802.3u, and 802.3ab PHY specifications compliant
  - Integrated PHY for 10/100/1000 Mbps for multispeed, full, and half-duplex auto-negotiation
  - IEEE 802.3x and 802.3z compliant flow control support with software-controllable Rx thresholds and Tx pause frames
  - Automatic cross-over detection function (MDI/MDI-X)
  - IEEE 1588 protocol and 802.1AS implementation
  - IEEE802.3az - Energy Efficient Ethernet (EEE)
  - Full wake up support
    - Advanced Power Management (APM) support
    - Advanced Configuration and Power Interface (ACPI) specification v2.0c
    - Magic packet wake-up enable
- I/O Virtualization Features:
  - Eight transmit (Tx) and receive (Rx) queue pairs per port
  - Flexible port partitioning: 32 virtual functions (VF) with four ports or 16 VFs with two ports
  - Rx/Tx round-robin scheduling
  - Traffic isolation and traffic steering
  - Virtual machine (VM) to VM packet forwarding (packet loopback)
  - MAC and VLAN anti-spoofing
  - Malicious driver detection
  - Storm control
  - Per-pool statistics, off loads, and jumbo support
  - Independent Function Level Reset (FLR) for physical and virtual functions
  - IEEE 802.1q Virtual Local Area Network (VLAN) support with VLAN tag insertion, stripping, and packet filtering for up to 4096 VLAN tags
  - IEEE 802.1q advanced packet filtering
  - Mirroring rules
  - Support for simple VEPA
  - VF promiscuous modes
- Stateless offload and performance features:
  - TCP/UDP, IPv4 checksum offloads (Rx/ Tx/Large-send); extended Tx descriptors
  - IPv6 support for IP/TCP and IP/UDP receive checksum offload
  - Tx TCP segmentation offload (IPv4, IPv6)
  - Transmit Segmentation Offloading (TSO)
  - Interrupt throttling control
  - Legacy and Message Signal Interrupt (MSI)
  - Message Signal Interrupt Extension (MSI-X)
  - Receive Side Scaling (RSS) for Windows
  - Scalable I/O for Linux environments (IPv4, IPv6, TCP/UDP)
  - Support for packets up to 9.5 KB (jumbo frames)

The following table lists additional supported network adapters.

Table 15. Network adapters

| Part number                            | Feature code | Description   | Maximum supported |
|--|--------------|---|-------------------|
| <b>40 Gb Ethernet / FDR InfiniBand</b> |              |   |                   |
| 00D9550                                | A3PN         | Mellanox ConnectX-3 40GbE / FDR IB VPI Adapter  | 4                 |
| <b>10 Gb Ethernet</b>                  |              |   |                   |
| 44T1370                                | A5GZ         | Broadcom NetXtreme 2x10GbE BaseT Adapter  | 4                 |
| 94Y5180                                | A4Z6         | Broadcom NetXtreme Dual Port 10GbE SFP+ Adapter   | 4*                |
| 00JY830                                | A5UU         | Emulex VFA5 2x10 GbE SFP+ Adapter and FCoE/iSCSI SW   | 4*                |
| None                                   | AS3M         | Emulex VFA5 2x10 GbE SFP+ Integrated Adapter  | 4*                |
| 00JY820                                | A5UT         | Emulex VFA5 2x10 GbE SFP+ PCIe Adapter  | 4*                |
| 00JY824                                | A5UV         | Emulex VFA5 FCoE/iSCSI SW for PCIe Adapter (FoD)<br>(Features on Demand upgrade for 00JY820 and feature AS3M) | 4                 |
| 49Y7960                                | A2EC         | Intel X520 Dual Port 10GbE SFP+ Adapter   | 4*                |
| 49Y7970                                | A2ED         | Intel X540-T2 Dual Port 10GBaseT Adapter  | 4                 |
| 81Y3520                                | AS73         | Intel X710 2x10GbE SFP+ Adapter   | 4*                |
| 00D9690                                | A3PM         | Mellanox ConnectX-3 10 GbE Adapter  | 4*                |
| 42C1800                                | 5751         | QLogic 10Gb CNA   | 4*                |
| 90Y4600                                | A3MR         | QLogic 8200 Dual Port 10GbE SFP+ VFA  | 4*                |
| 00Y5624                                | A3MT         | QLogic 8200 VFA FCoE/iSCSI License (FoD)<br>(Features on Demand upgrade for 90Y4600)                          | 4                 |
| 47C9952                                | A47H         | Solarflare SFN5162F 2x10GbE SFP+ Performant Adapter   | 4*                |
| <b>Integrated NIC upgrades</b>         |              |   |                   |
| 90Y9314                                | A2GT         | Intel I-350 Embedded Dual Port GbE Activation (FoD)   | 1                 |
| <b>Gigabit Ethernet</b>                |              |   |                   |
| 39Y6066                                | 1485         | Broadcom NetXtreme 1xGbE BaseT Adapter  | 4                 |
| 42C1780                                | 2995         | Broadcom NetXtreme 2xGbE BaseT Adapter  | 4                 |
| 90Y9370                                | A2V4         | Broadcom NetXtreme I Dual Port GbE Adapter  | 4                 |
| 90Y9352                                | A2V3         | Broadcom NetXtreme I Quad Port GbE Adapter  | 4                 |
| 49Y4230                                | 5767         | Intel Ethernet Dual Port Server Adapter I340-T2   | 4                 |
| 49Y4240                                | 5768         | Intel Ethernet Quad Port Server Adapter I340-T4   | 4                 |
| 00AG500                                | A56K         | Intel I350-F1 1xGbE Fiber Adapter   | 4                 |
| 00AG510                                | A56L         | Intel I350-T2 2xGbE BaseT Adapter   | 4                 |
| 00AG520                                | A56M         | Intel I350-T4 4xGbE BaseT Adapter   | 4                 |

\* These adapters require SFP+ optical transceivers or DAC cables that must be purchased separately.

For more information, see the list of Lenovo Press Product Guides in the Ethernet Adapters category:  
<http://lenovopress.com/servers/options/ethernet>

## Storage host bus adapters

The following table lists storage HBAs supported by the x3630 M4 server.

Table 16. Storage adapters

| Part number           | Feature code | Description                    | Maximum supported |
|-----------------------|--------------|--------------------------------|-------------------|
| Fibre Channel - 16 Gb |              |                                |                   |
| 81Y1662               | A2W6         | Emulex 16Gb FC Dual-port HBA   | 4                 |
| 81Y1655               | A2W5         | Emulex 16Gb FC Single-port HBA | 4                 |
| 00Y3341               | A3KX         | QLogic 16Gb FC Dual-port HBA   | 4                 |
| 00Y3337               | A3KW         | QLogic 16Gb FC Single-port HBA | 4                 |
| Fibre Channel - 8 Gb  |              |                                |                   |
| 42D0494               | 3581         | Emulex 8Gb FC Dual-port HBA    | 4                 |
| 42D0485               | 3580         | Emulex 8Gb FC Single-port HBA  | 4                 |
| 42D0510               | 3579         | QLogic 8Gb FC Dual-port HBA    | 4                 |
| 42D0501               | 3578         | QLogic 8Gb FC Single-port HBA  | 4                 |
| SAS                   |              |                                |                   |
| 46M0907               | 5982         | 6Gb SAS HBA                    | 4                 |
| 46C9010               | A3MV         | N2125 SAS/SATA HBA             | 2                 |
| 00AE912               | A5M0         | N2225 SAS/SATA HBA             | 4                 |
| 00AE916               | A5M1         | N2226 SAS/SATA HBA             | 1                 |

For more information, see the list of Lenovo Press Product Guides in the Host bus adapters category: <http://lenovopress.com/servers/options/hba>

## PCIe SSD adapters

The server supports the High IOPS SSD adapters listed in the following table.

Table 17. SSD adapters

| Part number      | Feature code | Description                               | Maximum supported |
|------------------|--------------|---|-------------------|
| Enterprise       |              |   |                   |
| 00AE995          | ARYP         | 1000GB Enterprise io3 Flash Adapter       | 4                 |
| 00AE998          | ARYQ         | 1300GB Enterprise io3 Flash Adapter       | 4                 |
| 00JY001          | ARYR         | 2600GB Enterprise io3 Flash Adapter       | 4                 |
| 00JY004          | ARYS         | 5200GB Enterprise io3 Flash Adapter       | 2                 |
| Enterprise Value |              |   |                   |
| 00AE983          | ARYK         | 1250GB Enterprise Value io3 Flash Adapter | 4                 |
| 00AE986          | ARYL         | 1600GB Enterprise Value io3 Flash Adapter | 4                 |
| 00AE989          | ARYM         | 3200GB Enterprise Value io3 Flash Adapter | 4                 |
| 00AE992          | ARYN         | 6400GB Enterprise Value io3 Flash Adapter | 2                 |

**Note:** The io3 Flash Adapters cannot be factory installed; they are supported as field-installable options only. The server cannot be shipped with these adapters installed.

For more information, see the list of Lenovo Press Product Guides in the PCIe SSD Adapters category: <http://lenovopress.com/servers/options/ssdadapter>

## GPU adapters

The server supports graphics processing units (GPUs) provided riser card 00Y7550 or FC A4LV is installed. The following table lists the supported GPUs.

Table 18. GPU adapters

| Part number | Feature code | Description         | Maximum supported |
|-------------|--------------|---------------------|-------------------|
| None*       | A3WH         | NVIDIA Quadro K600  | 1                 |
| None*       | A3WJ         | NVIDIA Quadro K2000 | 1                 |

\* This adapter can only be ordered through CTO or special bid.

The use of GPU adapters with 4x 3.5-inch or 8x 3.5-inch drive bay models requires installation of one or two 750 W power supplies. The use of GPU adapters with 12x 3.5-inch or 14x 3.5-inch drive bay models requires installation of one or two 900 W power supplies. 550 W power supplies are not supported with GPU adapters.

## Power supplies

The server supports up to two redundant hot-swap 550 W AC, 750 W AC, 900 W AC, or 750 W DC high efficient power supplies. AC power supplies are 80 PLUS Platinum certified. Standard models come with one 550 W AC (models with up to eight drive bays) or 750 W AC (storage-rich models with up to 14 drive bays) hot-swap power supply.

The following table lists the power supply options. An AC hot-swap power supply option ships standard with one 2.8m, 10A/100-250V, C13 to IEC 320-C14 rack power cable.

Table 19. Power supplies

| Part number | Feature code | Description  | Maximum supported | Standard models where used |
|-------------|--------------|--|-------------------|----------------------------|
| 94Y6668     | A1H6         | System x 550W High Efficiency Platinum AC Power Supply | 2                 | A3x, A5x, B3x, C3x, F5x    |
| 94Y6669     | A1H5         | System x 750W High Efficiency Platinum AC Power Supply | 2                 | B5x, D3x, G3x              |
| 94Y6667     | A2EB         | System x 900W High Efficiency Platinum AC Power Supply | 2                 | -                          |
| 94Y7631     | A39N         | System x 750W High Efficiency -48 V DC Power Supply    | 2                 | -                          |

**Note:** If you plan to use GPU adapters, refer to the "GPU adapters" section for the additional power supply selection guidelines.

## Integrated virtualization

The server supports VMware ESXi installed on a USB memory key. The key is installed in a USB socket inside the server. The following table lists the virtualization options.

Table 20. Virtualization options

| <b>Part number</b> | <b>Feature code</b> | <b>Description</b>                             | <b>Maximum supported</b> |
|--------------------|---------------------|--|--------------------------|
| 41Y8298            | A2G0                | Blank USB Memory Key for VMware ESXi Downloads | 1                        |
| 41Y8311            | A2R3                | USB Memory Key for VMware ESXi 5.1             | 1                        |
| 41Y8382            | A4WZ                | USB Memory Key for VMware ESXi 5.1 Update 1    | 1                        |
| 41Y8385            | A584                | USB Memory Key for VMware ESXi 5.5             | 1                        |

## Systems management

The server contains Integrated Management Module II (IMM2), which provides advanced service-processor control, monitoring, and an alerting function. If an environmental condition exceeds a threshold or if a system component fails, the IMM2 lights LEDs to help you diagnose the problem, records the error in the event log, and alerts you to the problem. Optionally, the IMM2 also provides a virtual presence capability for remote server management capabilities.

The IMM2 provides remote server management through industry-standard interfaces:

- Intelligent Platform Management Interface (IPMI) Version 2.0
- Simple Network Management Protocol (SNMP) Version 3
- Common Information Model (CIM)
- Web browser

The optional Integrated Management Module Advanced Upgrade is required to enable the remote presence and blue-screen capture features. The remote presence feature provides the following functions:

- Remotely viewing video with graphics resolutions up to 1600x1200 at 75 Hz with up to 23 bits per pixel, regardless of the system state
- Remotely accessing the server using the keyboard and mouse from a remote client
- Mapping the CD or DVD drive, diskette drive, and USB flash drive on a remote client, and mapping ISO and diskette image files as virtual drives that are available for use by the server
- Uploading a diskette image to the IMM memory and mapping it to the server as a virtual drive

The blue-screen capture feature captures the video display contents before the IMM restarts the server when the IMM detects an operating system hang condition. A system administrator can use the blue-screen capture to assist in determining the cause of the hang condition. The following table lists the remote management option.

Table 21. Remote management option

| Part number | Feature code | Description                                   | Maximum supported |
|-------------|--------------|---|-------------------|
| 90Y3901     | A1ML         | Integrated Management Module Advanced Upgrade | 1                 |

In the default UEFI configuration, Ethernet port 2 is configured to be dedicated to remote access to the IMM2. If preferred, you can change the UEFI setting so that remote access to the IMM2 is via Port 1 and also accessible to the operating system. This setting is also useful if you do not have a dedicated management network. The following table shows this setting and its effect on the Ethernet ports.

**Note:** The IMM2 network must operate 100 Mbps full duplex. The IMM2 network connection does not support Gigabit Ethernet. In shared mode, the production Ethernet network on that port still operates at Gigabit speeds.

Table 22. UEFI settings for remote access to the IMM

| UEFI mode                                      | Ethernet Port 1                           | Ethernet Port 2     | Ethernet Port 3 (optional) | Ethernet Port 4 (optional) |
|--|---|---------------------|----------------------------|----------------------------|
| IMM network interface port dedicated (default) | Production Ethernet                       | IMM2 dedicated*     | Production Ethernet        | Production Ethernet        |
| IMM network interface port shared              | Shared - Production Gb Ethernet and IMM2* | Production Ethernet | Production Ethernet        | Production Ethernet        |

\* The IMM network is limited to 100 Mbps full duplex

### Light path diagnostics panel

The light path diagnostics panel allows system engineers and administrators to easily and quickly diagnose hardware problems on the System x servers. If a failure occurs, a light is illuminated on the front panel of the server (level 1 light path) to alert the systems administrator that there is a problem. The pop-out light path diagnostics panel (light path level 2) has a light against the failed subsystem. This light directs the engineer or administrator directly to the failed component, which also has an illuminated LED near it (light path level 3), for example, the DIMM error LED on the system board.

x3630 M4 offers two variants of light path diagnostics: basic and advanced. All standard x3630 M4 models include basic functionality that provides light path levels 1 and 3. Advanced functionality is optional, and contains a pop-out panel that adds light path level 2. Storage-rich x3630 M4 servers (servers with 12 or 14 drive bays) only support basic light path.

The following figures show basic (level 1) and advanced (level 2) light path levels.

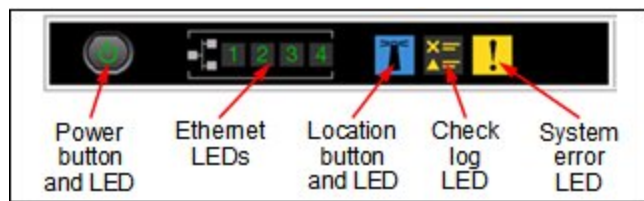

Figure 8. Basic (level 1) light path for models with

eight drive bays

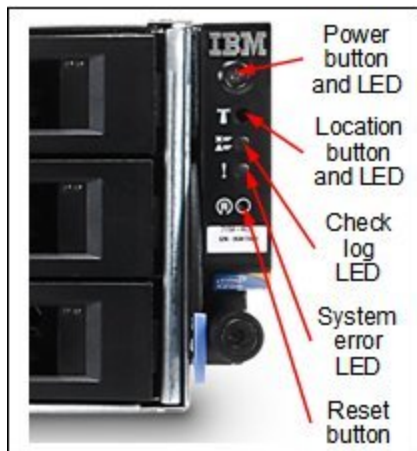

Figure 9. Basic (level 1) light path for storage-rich models

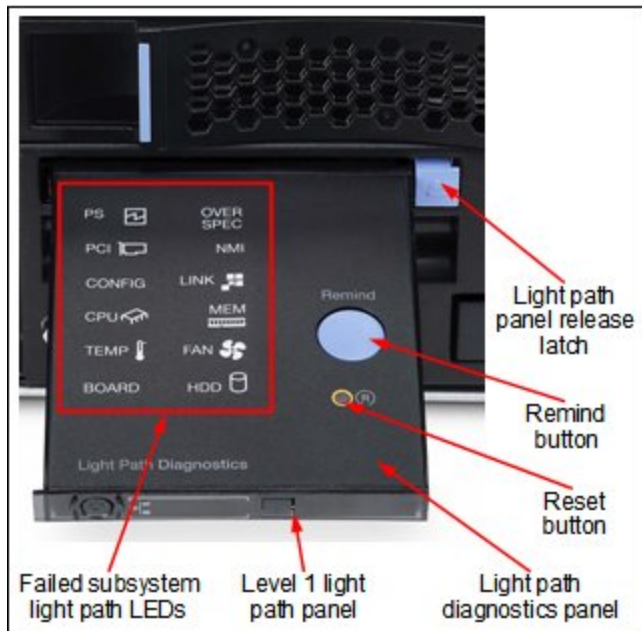

Figure 10. Advanced (level 2) light path for models with eight drive bays

The following table lists the advanced light path kit.

Table 23. Advanced light path kit

| Part number | Feature code | Description           | Maximum supported |
|-------------|--------------|-----------------------|-------------------|
| 90Y6533     | A2U6         | Lightpath Upgrade kit | 1                 |

## Operating systems

The server supports the following operating systems:

- Microsoft Windows Server 2008 R2
- Microsoft Windows Server 2008, Datacenter x64 Edition
- Microsoft Windows Server 2008, Datacenter x86 Edition
- Microsoft Windows Server 2008, Enterprise x64 Edition

- Microsoft Windows Server 2008, Standard x64 Edition
- Microsoft Windows Server 2008, Standard x86 Edition
- Microsoft Windows Server 2008, Web x64 Edition
- Microsoft Windows Server 2008, Web x86 Edition
- Microsoft Windows Server 2012
- Microsoft Windows Server 2012 R2
- Red Hat Enterprise Linux 5 Server Edition
- Red Hat Enterprise Linux 5 Server with Xen x64 Edition
- Red Hat Enterprise Linux 5 Server x64 Edition
- Red Hat Enterprise Linux 6 Server Edition
- Red Hat Enterprise Linux 6 Server x64 Edition
- Red Hat Enterprise Linux 7
- SUSE LINUX Enterprise Server 11 for x86
- SUSE LINUX Enterprise Server 11 with Xen for AMD64/EM64T
- SUSE Linux Enterprise Server 12
- SUSE Linux Enterprise Server 12 with XEN
- VMware vSphere 5.0 (ESXi)
- VMware vSphere 5.1 (ESXi)
- VMware vSphere 5.5 (ESXi)

For the latest information about the specific versions and service levels supported and any other prerequisites, see the ServerProven® website at:

<http://www.lenovo.com/us/en/serverproven/nos/matrix.shtml>

## Physical specifications

The server has the following dimensions and weight (approximate):

- Height: 86 mm (3.4 in.)
- Width: 447 mm (17.6 in.)
- Depth: 749 mm (29.5 in.)
- Weight:
  - Minimum configuration: 16.4 kg (36.2 lb).
  - Maximum configuration: 28.2 kg (62.2 lb).

## Operating environment

The server is supported in the following environment:

- Air temperature
  - Server on: 5 °C - 40 °C (41.0 °F - 104 °F); altitude: 0 - 915 m (3,000 ft).
  - Server on: 5 °C - 32 °C (41.0 °F - 89.6 °F); altitude: 915 - 2,134 m (7,000 ft).
  - Server on: 5 °C - 28 °C (41.0 °F - 82.4 °F); altitude: 2,134 - 3,050 m (10,000 ft).
  - Server off: 5 °C - 45 °C (41.0 °F - 113 °F).
  - Shipment: -40 °C - 60 °C (-40 °F - 140 °F).
- Humidity:
  - Server on: 8% - 85%, maximum dew point 24 °C, maximum rate of change 5 °C/hr.
  - Server off: 8% - 80%, maximum dew point 27 °C.
  - Shipment: 5% - 100%.
- Design to ASHRAE Class A3, ambient of 35 °C - 40 °C, with relaxed support:
  - Support cloud like workload with no performance degradation acceptable (Turbo-Off).
  - Under no circumstance can any combination of worst case workload and configuration result in system shutdown or design exposure at 40 °C.
- Electrical

- Models with 900 W AC hot-swap power supplies:
  - 100 to 127 (nominal) V ac; 50 Hz or 60 Hz; 10 A
  - 200 to 240 (nominal) V ac; 50 Hz or 60 Hz; 5 A
  - Input kilovolt-amperes (kVA) (approximately):
    - Minimum configuration: 0.14 kVA
    - Maximum configuration: 0.99 kVA
- Models with 750 W AC hot-swap power supplies:
  - 100 - 127 (nominal) V AC; 50 Hz or 60 Hz; 8.9 A
  - 200 - 240 (nominal) V AC; 50 Hz or 60 Hz; 4.5 A
  - Input kilovolt-amperes (kVA) (approximately):
    - Minimum configuration: 0.14 kVA
    - Maximum configuration: 0.85 kVA
- Models with 550 W AC hot-swap power supplies:
  - 100 - 127 (nominal) V AC; 50 Hz or 60 Hz; 6.5 A
  - 200 - 240 (nominal) V AC; 50 Hz or 60 Hz; 3.3 A
  - Input kilovolt-amperes (kVA) (approximately):
    - Minimum configuration: 0.12 kVA
    - Maximum configuration: 0.66 kVA
- Models with 750 W DC hot-swap power supplies:
  - -40 to -75 (nominal) V DC; 20.4 A
  - Input kilovolt-amperes (kVA) (approximately):
    - Minimum configuration: 0.14 kVA
    - Maximum configuration: 0.77 kVA
- BTU output
  - Minimum configuration: 406 Btu/hr (119 watts)
  - Maximum configuration: 3381 Btu/hr (990 watts)
- Noise level
  - 6.6 bels (operating).
  - 6.6 bels (idle).

## Warranty options

The x3630 M4 has a three-year warranty with 24x7 standard call center support and 9x5 Next Business Day onsite coverage. Also available are Lenovo Services warranty maintenance upgrades and post-warranty maintenance agreements, with a well-defined scope of services, including service hours, response time, term of service, and service agreement terms and conditions.

Lenovo warranty service upgrade offerings are country-specific. Not all warranty service upgrades are available in every country. For more information about Lenovo warranty service upgrade offerings that are available in your country, visit the Lenovo Services website:

<https://www-304.ibm.com/sales/gss/download/spst/servicepac>

The following table explains warranty service definitions in more detail.

Table 24. Warranty service definitions

| Term            | Description  |
|-----------------|--|
| On-site service | A service technician will arrive at the client's location for equipment service.   |
| 24x7x2 hour     | A service technician is scheduled to arrive at the client's location within two hours after remote problem determination is completed. Lenovo provides service around the clock, every day, including Lenovo holidays. |

|                       |   |
|-----------------------|---|
| 24x7x4 hour           | A service technician is scheduled to arrive at the client's location within four hours after remote problem determination is completed. Lenovo provides service around the clock, every day, including Lenovo holidays.   |
| 9x5x4 hour            | A service technician is scheduled to arrive at the client's location within four business hours after remote problem determination is completed. Lenovo provides service 8:00 am - 5:00 pm in the client's local time zone, Monday-Friday, excluding Lenovo holidays. For example, if a customer reports an incident at 3:00 pm on Friday, the technician will arrive by 10:00 am the following Monday.   |
| 9x5 next business day | A service technician is scheduled to arrive at the client's location on the business day after remote problem determination is completed. Lenovo provides service 8:00 am - 5:00 pm in the client's local time zone, Monday - Friday, excluding Lenovo holidays. Calls received after 4:00 pm local time require an extra business day for service dispatch. Next business day service is not guaranteed. |
| Committed Repair      | Problems receive priority handling so that repairs are completed within the committed time of 6, 8, or 24 hours. Lenovo provides service 24 hours/day, every day, including Lenovo holidays.  |

The following Lenovo warranty service upgrades are available:

- Warranty and maintenance service upgrades:
  - Three, four, or five years of 9x5 or 24x7 service coverage
  - Onsite response from next business day to 2 or 4 hours
  - Committed repair service
  - Warranty extension of up to 5 years
  - Post warranty extensions
- Committed Repair Service  
Committed Repair Services enhances the level of Warranty Service Upgrade or Post Warranty/Maintenance Service offering associated with the selected systems. Offerings vary and are available in select countries.
  - Priority handling to meet defined time frames to restore the failing machine to good working condition
  - Committed repair service levels are measured within the following coverage hours:
    - 24x7x6: Service performed 24 hours per day, 7 days per week, within 6 hours
    - 24x7x8: Service performed 24 hours per day, 7 days per week, within 8 hours
    - 24x7x24: Service performed 24 hours per day, 7 days per week, within 24 hours
- Hard Drive Retention  
Lenovo's Hard Drive Retention service is a multi-drive hard drive retention offering that ensures your data is always under your control, regardless of the number of hard drives that are installed in your Lenovo server. In the unlikely event of a hard drive failure, you retain possession of your hard drive while Lenovo replaces the failed drive part. Your data stays safely on your premises, in your hands. The Hard Drive Retention service can be purchased in convenient bundles with our warranty upgrades and extensions.
- Microcode Support  
Keeping microcode current helps prevent hardware failures and security exposure. There are two levels of service: analysis of the installed base and analysis and update where required. Offerings vary by country and can be bundled with other warranty upgrades and extensions.
- Remote Technical Support Services (RTS)  
RTS provides comprehensive technical call center support for covered servers, storage, operating systems, and applications. Providing a single source for support of hardware and software issues, RTS can reduce problem resolution time, decreasing the cost to address technical problems and increasing uptime. Offerings are available for Windows, Linux, IBM Systems Director, VMware, Microsoft business applications, and Lenovo System x storage devices, and IBM OEM storage devices.

## Regulatory compliance

The server conforms to the following regulations:

- FCC - Verified to comply with Part 15 of the FCC Rules, Class A
- Canada ICES-003, issue 4, Class A
- UL/IEC 60950-1
- CSA C22.2 No. 60950-1
- NOM-019
- Argentina IEC60950-1
- Japan VCCI, Class A
- Australia/New Zealand AS/NZS CISPR 22, Class A
- IEC 60950-1(CB Certificate and CB Test Report)
- China CCC (GB4943), GB9254 Class A, GB17625.1
- Taiwan BSMI CNS13438, Class A; CNS14336-1
- Korea KN22, Class A; KN24

- Russia, Belorussia and Kazakhstan, TR CU 020/2011 (for EMC) and TR CU 004/2011 (for safety)
- CE Mark (EN55022 Class A, EN60950-1, EN55024, EN61000-3-2, and EN61000-3-3)
- CISPR 22, Class A
- TUV-GS (EN60950-1 /IEC60950-1,EK1-ITB2000)

## External disk storage expansion

The x3630 M4 supports attachments to the external storage expansion enclosures using the RAID controllers that are listed in the following table.

Table 25. Ordering part numbers and feature codes

| Part number                                     | Feature code | Description  | Maximum supported |
|---|--------------|--|-------------------|
| Adapters  |              |  |                   |
| 00AE938   | A5ND         | ServeRAID M5225-2GB SAS/SATA Controller            | 4                 |
| 81Y4478   | A1WX         | ServeRAID M5120 SAS/SATA Controller                | 4                 |
| Hardware upgrades for the M5120#                |              |  |                   |
| 81Y4484   | A1J3         | ServeRAID M5100 Series 512MB Cache/RAID 5 Upgrade  | 4                 |
| 81Y4487   | A1J4         | ServeRAID M5100 Series 512MB Flash/RAID 5 Upgrade  | 2*                |
| 81Y4559   | A1WY         | ServeRAID M5100 Series 1GB Flash/RAID 5 Upgrade    | 2*                |
| 47C8670   | A4G6         | ServeRAID M5100 Series 2GB Flash/RAID 5 Upgrade    | 1                 |
| 81Y4508   | A22E         | ServeRAID M5100 Series Battery Kit                 | 2*                |
| Features on Demand (FoD) upgrades for the M5120 |              |  |                   |
| 81Y4546   | A1X3         | ServeRAID M5100 Series RAID 6 Upgrade              | 1**               |
| 90Y4273   | A2MC         | ServeRAID M5100 Series SSD Performance Accelerator | 1**               |
| 90Y4318   | A2MD         | ServeRAID M5100 Series SSD Caching Enabler         | 1**               |

# One of the available cache upgrades (81Y4484, 81Y4487, 81Y4559, or 47C8670) is required for the M5120 adapter.

\* Total number of all Flash Upgrades and Battery Kits installed in a single server must not exceed two.

\*\* One M5100 Series FoD software license activates the feature on all M5100 series controllers installed in a server.

The ServeRAID M5120 SAS/SATA Controller has the following specifications:

- Eight external 6 Gbps SAS/SATA ports; up to 6 Gbps throughput per port
- Two external x4 mini-SAS connectors (SFF-8088)
- Supports RAID levels 0, 1, and 10
- Supports RAID levels 5 and 50 with optional M5100 Series RAID 5 upgrades
- Supports RAID 6 and 60 with the optional M5100 Series RAID 6 Upgrade
- Supports 512 MB battery-backed cache or 512 MB, 1 GB, or 2 GB flash-backed cache (cache)
- PCIe 3.0 x8 host interface
- Based on the LSI SAS2208 6 Gbps ROC controller
- Supports connectivity to the EXP2512 and EXP2524 storage expansion enclosures

For more information, see the Lenovo Press Product Guide *ServeRAID M5120 SAS/SATA Controller*:

<http://lenovopress.com/tips0858>

The ServeRAID M5225-2GB SAS/SATA Controller has the following specifications:

- Eight external 12 Gbps SAS/SATA ports
- Two external x4 mini-SAS HD connectors (SFF-8643)
- Supports RAID levels 0, 1, 10, 5, 50 standard
- 2 GB flash-backed cache standard
- PCIe x8 3.0 host interface
- Based on the LSI SAS3108 12 Gbps ROC controller

For more information about the ServeRAID M5225, see the Lenovo Press Product Guide at <http://lenovopress.com/tips1258>

The M5120 supports connectivity to the external expansion enclosures that are listed in the following table. Up to nine expansion enclosures can be daisy-chained per one adapter port. For better performance, distribute expansion enclosures evenly across both adapter ports.

Table 26. External expansion enclosures

| Part number | Description               | Maximum quantity supported per one M5120 |
|-------------|---------------------------|--|
| 70F0 / 70F1 | Lenovo ThinkServer SA120  | 8  |
| 610012X     | EXP2512 Storage Enclosure | 17                                       |
| 610024X     | EXP2524 Storage Enclosure | 9  |

### Lenovo ThinkServer SA120 support

For details about supported drives and cables for the Lenovo ThinkServer SA120, see the Lenovo Press Product Guide: <http://lenovopress.com/tips1234>

### EXP2512 and EXP2524 support

The external SAS cables listed in the following table support connectivity between external expansion enclosures and the controller.

Table 27. External SAS cables for external storage expansion enclosures

| Part number  | Description                      | Maximum quantity supported per one enclosure |
|--|----------------------------------|--|
| ServeRAID M5120 - Server to Expansion enclosure connectivity (Mini-SAS x4 to Mini-SAS x4)    |                                  |  |
| 00WC017  | 1 m SAS Cable                    | 1  |
| 00WC018  | 3 m SAS Cable                    | 1  |
| ServeRAID M5225 - Server to Expansion enclosure connectivity (Mini-SAS HD x4 to Mini-SAS x4) |                                  |  |
| 00MJ162  | 0.6m SAS Cable (mSAS HD to mSAS) | 1  |
| 00MJ163  | 1.5m SAS Cable (mSAS HD to mSAS) | 1  |
| 00MJ166  | 3m SAS Cable (mSAS HD to mSAS)   | 1  |
| Expansion enclosure to Expansion enclosure connectivity (Mini-SAS x4 to Mini-SAS x4)         |                                  |  |
| 00WC017  | 1 m SAS Cable                    | 1  |
| 00WC018  | 3 m SAS Cable                    | 1  |

The following table lists the drives that are supported by EXP2512 external expansion enclosures.

Table 28. Drive options for EXP2512 external expansion enclosures

| Part number                | Description                       | Maximum quantity supported per one enclosure |
|----------------------------|-----------------------------------|--|
| <b>3.5" NL SAS HS HDDs</b> |                                   |  |
| 00NC555                    | 2TB 7,200 rpm 6Gb SAS NL 3.5" HDD | 12   |
| 00NC557                    | 3TB 7,200 rpm 6Gb SAS NL 3.5" HDD | 12   |
| 00NC559                    | 4TB 7,200 rpm 6Gb SAS NL 3.5" HDD | 12   |

The following table lists the hard disk drives that are supported by EXP2524 external expansion enclosures.

Table 29. Drive options for EXP2524 external expansion enclosures

| Part number                | Description                       | Maximum quantity supported per one enclosure |
|----------------------------|-----------------------------------|--|
| <b>2.5" NL SAS HS HDDs</b> |                                   |  |
| 00NC571                    | 1TB 7,200 rpm 6Gb SAS NL 2.5" HDD | 24   |
| <b>2.5" SAS HS HDDs</b>    |                                   |  |
| 00NC561                    | 146GB 15,000 rpm 6Gb SAS 2.5" HDD | 24   |
| 00NC563                    | 300GB 15,000 rpm 6Gb SAS 2.5" HDD | 24   |
| 00NC565                    | 600GB 10,000 rpm 6Gb SAS 2.5" HDD | 24   |
| 00NC567                    | 900GB 10,000 rpm 6Gb SAS 2.5" HDD | 24   |
| 00NC569                    | 1.2TB 10,000 rpm 6Gb SAS 2.5" HDD | 24   |
| <b>2.5" SAS HS SSDs</b>    |                                   |  |
| 00NC573                    | 200GB 6Gb SAS 2.5" SSD            | 24   |
| 00NC575                    | 400GB 6Gb SAS 2.5" SSD            | 24   |

## External disk storage systems

The following table lists the external storage systems that are offered by Lenovo that can be used in x3630 M4 solutions.

Table 30. External disk storage systems

| Part number                 | Description   |
|-----------------------------|---|
| <b>Lenovo Storage S2200</b> |   |
| 64112B1                     | Lenovo Storage S2200 LFF Chassis SAS Single Controller, Rack Kit, 9x5NBD      |
| 64112B2                     | Lenovo Storage S2200 LFF Chassis SAS Dual Controller, Rack Kit, 9x5NBD        |
| 64114B1                     | Lenovo Storage S2200 LFF Chassis FC/iSCSI Single Controller, Rack Kit, 9x5NBD |
| 64114B2                     | Lenovo Storage S2200 LFF Chassis FC/iSCSI Dual Controller, Rack Kit, 9x5NBD   |
| 64112B3                     | Lenovo Storage S2200 SFF Chassis SAS Single Controller, Rack Kit, 9x5NBD      |
| 64112B4                     | Lenovo Storage S2200 SFF Chassis SAS Dual Controller, Rack Kit, 9x5NBD        |
| 64114B3                     | Lenovo Storage S2200 SFF Chassis FC/iSCSI Single Controller, Rack Kit, 9x5NBD |
| 64114B4                     | Lenovo Storage S2200 SFF Chassis FC/iSCSI Dual Controller, Rack Kit, 9x5NBD   |
| <b>Lenovo Storage S3200</b> |   |

| Part number  | Description   |
|--------------|---|
| 64113B1      | Lenovo Storage S3200 LFF Chassis SAS Single Controller, Rack Kit, 9x5NBD      |
| 64113B2      | Lenovo Storage S3200 LFF Chassis SAS Dual Controller, Rack Kit, 9x5NBD        |
| 64116B1      | Lenovo Storage S3200 LFF Chassis FC/iSCSI Single Controller, Rack Kit, 9x5NBD |
| 64116B2      | Lenovo Storage S3200 LFF Chassis FC/iSCSI Dual Controller, Rack Kit, 9x5NBD   |
| 64113B3      | Lenovo Storage S3200 SFF Chassis SAS Single Controller, Rack Kit, 9x5NBD      |
| 64113B4      | Lenovo Storage S3200 SFF Chassis SAS Dual Controller, Rack Kit, 9x5NBD        |
| 64116B3      | Lenovo Storage S3200 SFF Chassis FC/iSCSI Single Controller, Rack Kit, 9x5NBD |
| 64116B4      | Lenovo Storage S3200 SFF Chassis FC/iSCSI Dual Controller, Rack Kit, 9x5NBD   |
| IBM Storwize |   |
| 6096CU2      | IBM Storwize V3500 3.5-inch Dual Control Storage Controller Unit              |
| 6096CU3      | IBM Storwize V3500 2.5-inch Dual Control Storage Controller Unit              |
| 6099L2C      | IBM Storwize V3700 3.5-inch Storage Controller Unit                           |
| 6099S2C      | IBM Storwize V3700 2.5-inch Storage Controller Unit                           |
| 6099T2C      | IBM Storwize V3700 2.5-inch DC Storage Controller Unit                        |
| 6194L2C      | IBM Storwize V5000 LFF Control Enclosure                                      |
| 6194S2C      | IBM Storwize V5000 SFF Control Enclosure                                      |
| 6195SC5      | IBM Storwize V7000 2.5-inch Storage Controller Unit                           |

For more information, see the list of Product Guides in the following categories:

- Lenovo Storage  
<https://lenovopress.com/storage/san/lenovo>
- IBM Storage  
<https://lenovopress.com/storage/san/ibm>

## External backup units

The following table lists the external backup options that are offered by Lenovo that can be used in x3630 M4 solutions.

Table 31. External backup options

| Part number                                       | Description                                    |
|---|--|
| External tape enclosures                          |  |
| 61901UX   | IBM Multimedia Backup Enclosure                |
| Backup drives for IBM Multimedia Backup Enclosure |  |
| 00NV402   | 6190 HH LTO5 SAS Tape Drive                    |
| 00NV404   | 6190 HH LTO6 SAS Tape Drive                    |
| 00NV406   | 6190 RDX 3.0 Dock/320GB Cartridge Bundle       |
| 00NV407   | 6190 RDX 3.0 Dock/500GB Cartridge Bundle       |
| 00NV408   | 6190 RDX 3.0 Dock/1.0TB Cartridge Bundle       |
| 00NV455   | 6190 RDX 3.0 Dock/2.0TB Cartridge Bundle       |
| External backup units                             |  |
| 362532Y   | RDX External USB 3.0 Dock with 320GB Cartridge |
| 362550Y   | RDX External USB 3.0 Dock with 500GB Cartridge |
| 36251TY   | RDX External USB 3.0 Dock with 1TB Cartridge   |

| <b>Part number</b>  | <b>Description</b>                            |
|---|---|
| 6160S6X   | IBM TS2360 Tape Drive Model S63               |
| 6160S6E   | IBM TS2260 Tape Drive Model H6S               |
| 6160S5E   | IBM TS2250 Tape Drive Model H5S               |
| 6171S4R   | IBM TS2900 Tape Autoloader w/LTO4 HH SAS      |
| 6171S5R   | IBM TS2900 Tape Autoloader w/LTO5 HH SAS      |
| 6171S6R   | IBM TS2900 Tape Autoloader w/LTO6 HH SAS      |
| 61732UL   | IBM TS3100 Tape Library Model L2U             |
| 61734UL   | IBM TS3200 Tape Library Model L4U             |
| <b>Fibre Channel backup drives for TS3100 and TS3200 Tape Libraries</b> |   |
| 00NA101   | 6173 LTO Ultrium 4 Fibre Channel Drive Sled   |
| 00NA103   | 6173 LTO Ultrium 4 Half High Fibre Drive Sled |
| 00NA107   | 6173 LTO Ultrium 5 Fibre Channel Drive        |
| 00NA113   | 6173 LTO Ultrium 5 Half High Fibre Drive Sled |
| 00NA115   | 6173 LTO Ultrium 6 Fibre Channel Drive        |
| 00NA119   | 6173 LTO Ultrium 6 Half High Fibre Drive Sled |
| <b>SAS backup drives for TS3100 and TS3200 Tape Libraries</b>           |   |
| 00NA121   | 6173 LTO Ultrium 4 SAS Drive Sled             |
| 00NA105   | 6173 LTO Ultrium 4 Half High SAS DriveV2 Sled |
| 00NA109   | 6173 LTO Ultrium 5 SAS Drive Sled             |
| 00NA111   | 6173 LTO Ultrium 5 Half High SAS Drive Sled   |
| 00NA117   | 6173 LTO Ultrium 6 Half High SAS Drive Sled   |

For more information, see the list of Product Guides in the Backup Units category:  
<http://lenovopress.com/servers/options/backup>

## Top-of-rack Ethernet switches

The following table lists the top-of-rack Ethernet switches that are offered by Lenovo that can be used in x3630 M4 solutions.

Table 32. Top-of-rack switches

| Part number                         | Description                               |
|-------------------------------------|---|
| 1 Gb Ethernet top-of-rack switches  |   |
| 7159BAX                             | Lenovo RackSwitch G7028 (Rear to Front)   |
| 7159CAX                             | Lenovo RackSwitch G7052 (Rear to Front)   |
| 7159G52                             | Lenovo RackSwitch G8052 (Rear to Front)   |
| 10 Gb Ethernet top-of-rack switches |   |
| 7159BR6                             | Lenovo RackSwitch G8124E (Rear to Front)  |
| 7159G64                             | Lenovo RackSwitch G8264 (Rear to Front)   |
| 7159DRX                             | Lenovo RackSwitch G8264CS (Rear to Front) |
| 7159CRW                             | Lenovo RackSwitch G8272 (Rear to Front)   |
| 7159GR6                             | Lenovo RackSwitch G8296 (Rear to Front)   |
| 40 Gb Ethernet top-of-rack switches |   |
| 7159BRX                             | Lenovo RackSwitch G8332 (Rear to Front)   |

For more information, see the list of Product Guides in the Top-of-rack switches category:  
<http://lenovopress.com/servers/options/switches>

## Uninterruptible power supply units

The following table lists the uninterruptible power supply (UPS) units that are offered by Lenovo that can be used in x3630 M4 solutions.

Table 33. Uninterruptible power supply units

| Part number | Description   |
|-------------|---|
| 55941AX     | RT1.5kVA 2U Rack or Tower UPS (100-125VAC)          |
| 55941KX     | RT1.5kVA 2U Rack or Tower UPS (200-240VAC)          |
| 55942AX     | RT2.2kVA 2U Rack or Tower UPS (100-125VAC)          |
| 55942KX     | RT2.2kVA 2U Rack or Tower UPS (200-240VAC)          |
| 55943AX     | RT3kVA 2U Rack or Tower UPS (100-125VAC)            |
| 55943KX     | RT3kVA 2U Rack or Tower UPS (200-240VAC)            |
| 55945KX     | RT5kVA 3U Rack or Tower UPS (200-240VAC)            |
| 55946KX     | RT6kVA 3U Rack or Tower UPS (200-240VAC)            |
| 55948KX     | RT8kVA 6U Rack or Tower UPS (200-240VAC)            |
| 55949KX     | RT11kVA 6U Rack or Tower UPS (200-240VAC)           |
| 55948PX     | RT8kVA 6U 3:1 Phase Rack or Tower UPS (380-415VAC)  |
| 55949PX     | RT11kVA 6U 3:1 Phase Rack or Tower UPS (380-415VAC) |

For more information, see the list of Product Guides in the Uninterruptible Power Supply Units category: <http://lenovopress.com/servers/options/ups>

## Power distribution units

The following table lists the power distribution units (PDUs) that are offered by Lenovo that can be used in x3630 M4 solutions.

Table 34. Power distribution units

| Part number                        | Description   |
|------------------------------------|---|
| <b>0U Basic PDUs</b>               |   |
| 46M4122                            | 0U 24 C13 16A 3 Phase PDU with IEC 309 P+N+Gnd line cord                            |
| 46M4125                            | 0U 24 C13 30A 3 Phase PDU with NEMA L21-30P line cord                               |
| 46M4128                            | 0U 24 C13 30A PDU with NEMA L6-30P line cord  |
| 46M4131                            | 0U 24 C13 32A PDU with IEC 309 P+N+Gnd line cord                                    |
| 46M4143                            | 0U 12 C19/12 C13 32A 3 Phase PDU with IEC 309 3P+N+Gnd line cord                    |
| 46M4140                            | 0U 12 C19/12 C13 60A 3 Phase PDU with CS8365L 3P+Gnd line cord                      |
| <b>Switched and Monitored PDUs</b> |   |
| 46M4002                            | 1U 9 C19/3 C13 Switched and Monitored DPI PDU (without line cord)                   |
| 46M4003                            | 1U 9 C19/3 C13 Switched and Monitored 60A 3 Phase PDU with IEC 309 3P+Gnd line cord |
| 46M4004                            | 1U 12 C13 Switched and Monitored DPI PDU (without line cord)                        |
| 46M4005                            | 1U 12 C13 Switched and Monitored 60A 3 Phase PDU with IEC 309 3P+Gnd line cord      |
| 46M4167                            | 1U 9 C19/3 C13 Switched and Monitored 30A 3 Phase PDU with NEMA L21-30P line cord   |
| 46M4116                            | 0U 24 C13 Switched and Monitored 30A PDU with NEMA L6-30P line cord                 |

| <b>Part number</b>   | <b>Description</b>   |
|--|--|
| 46M4119  | 0U 24 C13 Switched and Monitored 32A PDU with IEC 309 P+N+Gnd line cord            |
| 46M4137  | 0U 12 C19/12 C13 Switched and Monitored 32A 3 Phase PDU with IEC 309 3P+N+Gnd cord |
| 46M4134  | 0U 12 C19/12 C13 Switched and Monitored 50A 3 Phase PDU with CS8365L 3P+Gnd cord   |
| <b>Ultra Density Enterprise PDUs (9x IEC 320 C13 + 3x IEC 320 C19 outlets)</b> |  |
| 71762NX  | Ultra Density Enterprise C19/C13 PDU Module (without line cord)                    |
| 71762MX  | Ultra Density Enterprise C19/C13 PDU+ Module (without line cord)                   |
| 71763NU  | Ultra Density Enterprise C19/C13 PDU 60A/208V/3ph with IEC 309 3P+Gnd line cord    |
| 71763MU  | Ultra Density Enterprise C19/C13 PDU+ 60A/208V/3ph with IEC 309 3P+Gnd line cord   |
| <b>C13 Enterprise PDUs (12x IEC 320 C13 outlets)</b>                           |  |
| 39M2816  | DPI C13 Enterprise PDU+ (without line cord)  |
| 39Y8941  | DPI Single Phase C13 Enterprise PDU (without line cord)                            |
| <b>C19 Enterprise PDUs (6x IEC 320 C19 outlets)</b>                            |  |
| 39Y8948  | DPI Single Phase C19 Enterprise PDU (without line cord)                            |
| 39Y8923  | DPI 60A 3 Phase C19 Enterprise PDU with IEC 309 3P+G (208 V) fixed line cord       |
| <b>Front-end PDUs (3x IEC 320 C19 outlets)</b>                                 |  |
| 39Y8938  | DPI 30amp/125V Front-end PDU with NEMA L5-30P line cord                            |
| 39Y8939  | DPI 30amp/250V Front-end PDU with NEMA L6-30P line cord                            |
| 39Y8934  | DPI 32amp/250V Front-end PDU with IEC 309 2P+Gnd line cord                         |
| 39Y8940  | DPI 60amp/250V Front-end PDU with IEC 309 2P+Gnd line cord                         |
| 39Y8935  | DPI 63amp/250V Front-end PDU with IEC 309 2P+Gnd line cord                         |
| <b>Universal PDUs (7x IEC 320 C13 outlets)</b>                                 |  |
| 39Y8951  | DPI Universal Rack PDU with US LV and HV line cords                                |
| 39Y8952  | DPI Universal Rack PDU with CEE7-VII Europe line cord                              |
| 39Y8953  | DPI Universal Rack PDU with Denmark line cord                                      |
| 39Y8954  | DPI Universal Rack PDU with Israel line cord                                       |
| 39Y8955  | DPI Universal Rack PDU with Italy line cord  |
| 39Y8956  | DPI Universal Rack PDU with South Africa line cord                                 |
| 39Y8957  | DPI Universal Rack PDU with UK line cord   |
| 39Y8958  | DPI Universal Rack PDU with AS/NZ line cord  |
| 39Y8959  | DPI Universal Rack PDU with China line cord  |
| 39Y8962  | DPI Universal Rack PDU (Argentina)   |
| 39Y8960  | DPI Universal Rack PDU (Brazil)  |
| 39Y8961  | DPI Universal Rack PDU (India)   |
| <b>NEMA PDUs (6x NEMA 5-15R outlets)</b>                                       |  |
| 39Y8905  | DPI 100-127V PDU with Fixed NEMA L5-15P line cord                                  |
| <b>Line cords for PDUs that ship without a line cord</b>                       |  |
| 40K9611  | DPI 32a Line Cord (IEC 309 3P+N+G)   |
| 40K9612  | DPI 32a Line Cord (IEC 309 P+N+G)  |
| 40K9613  | DPI 63a Cord (IEC 309 P+N+G)   |
| 40K9614  | DPI 30a Line Cord (NEMA L6-30P)  |
| 40K9615  | DPI 60a Cord (IEC 309 2P+G)  |
| 40K9617  | DPI Australian/NZ 3112 Line Cord   |

| Part number | Description               |
|-------------|---------------------------|
| 40K9618     | DPI Korean 8305 Line Cord |

For more information, see the list of Product Guides in the Power Distribution Units category:  
<http://lenovopress.com/servers/options/pdu>

## Rack cabinets

The following table lists the rack cabinets that are offered by Lenovo that can be used in x3630 M4 solutions.

Table 35. Rack cabinets

| Part number | Description                                     |
|-------------|---|
| 201886X     | 11U Rack Office Enablement Kit                  |
| 93072RX     | 25U S2 Standard Rack                            |
| 93072PX     | 25U Static S2 Standard Rack                     |
| 93074RX     | 42U S2 Standard Rack                            |
| 93634PX     | 42U 1100mm Enterprise V2 Dynamic Rack           |
| 93634EX     | 42U 1100mm Enterprise V2 Dynamic Expansion Rack |
| 93604PX     | 42U 1200mm Deep Dynamic Rack                    |
| 93614PX     | 42U 1200mm Deep Static Rack                     |
| 93084PX     | 42U Enterprise Rack                             |
| 93084EX     | 42U Enterprise Expansion Rack                   |

For more information, see the list of Product Guides in the Rack cabinets category:  
<http://lenovopress.com/servers/options/racks>

## Rack options

The x3630 M4 server supports the rack options listed in the following table.

Table 36. Rack options

| Description                                 | Part number |
|---|-------------|
| Monitor kits and keyboard trays             |             |
| 1U 18.5" Standard Console                   | 17238BX     |
| 1U 18.5" Enhanced Media Console             | 17238EX     |
| Console switches                            |             |
| Global 4x2x32 Console Manager (GCM32)       | 1754D2X     |
| Global 2x2x16 Console Manager (GCM16)       | 1754D1X     |
| Local 2x16 Console Manager (LCM16)          | 1754A2X     |
| Local 1x8 Console Manager (LCM8)            | 1754A1X     |
| Console cables                              |             |
| Single Cable USB Conversion Option (UCO)    | 43V6147     |
| USB Conversion Option (4 Pack UCO)          | 39M2895     |
| Virtual Media Conversion Option Gen2 (VCO2) | 46M5383     |
| Serial Conversion Option (SCO)              | 46M5382     |

For more information, see the list of Product Guides in the KVM Switches and Consoles category:  
<http://lenovopress.com/servers/options/kvm>

## Lenovo Financial Services

Lenovo Financial Services reinforces Lenovo's commitment to deliver pioneering products and services that are recognized for their quality, excellence, and trustworthiness. Lenovo Financial Services offers financing solutions and services that complement your technology solution anywhere in the world.

We are dedicated to delivering a positive finance experience for customers like you who want to maximize your purchase power by obtaining the technology you need today, protect against technology obsolescence, and preserve your capital for other uses.

We work with businesses, non-profit organizations, governments and educational institutions to finance their entire technology solution. We focus on making it easy to do business with us. Our highly experienced team of finance professionals operates in a work culture that emphasizes the importance of providing outstanding customer service. Our systems, processes and flexible policies support our goal of providing customers with a positive experience.

We finance your entire solution. Unlike others, we allow you to bundle everything you need from hardware and software to service contracts, installation costs, training fees, and sales tax. If you decide weeks or months later to add to your solution, we can consolidate everything into a single invoice.

Our Premier Client services provide large accounts with special handling services to ensure these complex transactions are serviced properly. As a premier client, you have a dedicated finance specialist who manages your account through its life, from first invoice through asset return or purchase. This specialist develops an in-depth understanding of your invoice and payment requirements. For you, this dedication provides a high-quality, easy, and positive financing experience.

For your region specific offers please ask your Lenovo sales representative or your technology provider

about the use of Lenovo Financial Services. For more information, see the following Lenovo website:  
<http://www.lenovofs.com>

## Related publications and links

For more information, see these resources:

- US Announcement Letter - System x3630 M4 (E5-2400 v2):  
<http://ibm.com/common/ssi/cgi-bin/ssialias?infotype=dd&subtype=ca&&htmlfid=897/ENUS114-019>
- Lenovo Press Product Guides for servers and options:  
<http://lenovopress.com>
- *System x3630 M4 Installation and User's Guide*:
- <http://ibm.com/support/entry/portal/docdisplay?Indocid=MIGR-5090171>
- *System x3630 M4 Problem Determination and Service Guide*:  
<http://ibm.com/support/entry/portal/docdisplay?Indocid=MIGR-5090165>
- ServerProven hardware compatibility page for the x3630 M4:  
<http://www.lenovo.com/us/en/serverproven/xseries/7158CE5CxxxV2.shtml>
- *Configuration and Option Guide*:  
<http://www.ibm.com/systems/xbc/cog/>
- xREF - System x Reference Sheets:  
<http://lenovopress.com/xref>
- System x3630 M4 Support Portal:  
[http://www.ibm.com/support/entry/portal/product/system\\_x/system\\_x3630\\_m4](http://www.ibm.com/support/entry/portal/product/system_x/system_x3630_m4)
- IBM System Storage Interoperation Center:  
<http://www.ibm.com/systems/support/storage/ssic>

## Related product families

Product families related to this document are the following:

- [2-Socket Rack Servers](#)

## Notices

Lenovo may not offer the products, services, or features discussed in this document in all countries. Consult your local Lenovo representative for information on the products and services currently available in your area. Any reference to a Lenovo product, program, or service is not intended to state or imply that only that Lenovo product, program, or service may be used. Any functionally equivalent product, program, or service that does not infringe any Lenovo intellectual property right may be used instead. However, it is the user's responsibility to evaluate and verify the operation of any other product, program, or service. Lenovo may have patents or pending patent applications covering subject matter described in this document. The furnishing of this document does not give you any license to these patents. You can send license inquiries, in writing, to:

Lenovo (United States), Inc.  
8001 Development Drive  
Morrisville, NC 27560  
U.S.A.  
Attention: Lenovo Director of Licensing

LENOVO PROVIDES THIS PUBLICATION "AS IS" WITHOUT WARRANTY OF ANY KIND, EITHER EXPRESS OR IMPLIED, INCLUDING, BUT NOT LIMITED TO, THE IMPLIED WARRANTIES OF NON-INFRINGEMENT, MERCHANTABILITY OR FITNESS FOR A PARTICULAR PURPOSE. Some jurisdictions do not allow disclaimer of express or implied warranties in certain transactions, therefore, this statement may not apply to you.

This information could include technical inaccuracies or typographical errors. Changes are periodically made to the information herein; these changes will be incorporated in new editions of the publication. Lenovo may make improvements and/or changes in the product(s) and/or the program(s) described in this publication at any time without notice.

The products described in this document are not intended for use in implantation or other life support applications where malfunction may result in injury or death to persons. The information contained in this document does not affect or change Lenovo product specifications or warranties. Nothing in this document shall operate as an express or implied license or indemnity under the intellectual property rights of Lenovo or third parties. All information contained in this document was obtained in specific environments and is presented as an illustration. The result obtained in other operating environments may vary. Lenovo may use or distribute any of the information you supply in any way it believes appropriate without incurring any obligation to you.

Any references in this publication to non-Lenovo Web sites are provided for convenience only and do not in any manner serve as an endorsement of those Web sites. The materials at those Web sites are not part of the materials for this Lenovo product, and use of those Web sites is at your own risk. Any performance data contained herein was determined in a controlled environment. Therefore, the result obtained in other operating environments may vary significantly. Some measurements may have been made on development-level systems and there is no guarantee that these measurements will be the same on generally available systems. Furthermore, some measurements may have been estimated through extrapolation. Actual results may vary. Users of this document should verify the applicable data for their specific environment.

© Copyright Lenovo 2026. All rights reserved.

This document, TIPS1145, was created or updated on December 9, 2015.

Send us your comments in one of the following ways:

- Use the online Contact us review form found at:  
<https://lenovopress.lenovo.com/TIPS1145>
- Send your comments in an e-mail to:  
[comments@lenovopress.com](mailto:comments@lenovopress.com)

This document is available online at <https://lenovopress.lenovo.com/TIPS1145>.

## Trademarks

Lenovo and the Lenovo logo are trademarks or registered trademarks of Lenovo in the United States, other countries, or both. A current list of Lenovo trademarks is available on the Web at <https://www.lenovo.com/us/en/legal/copytrade/>.

The following terms are trademarks of Lenovo in the United States, other countries, or both:

Lenovo®  
ServerProven®  
System x®  
ThinkServer®

The following terms are trademarks of other companies:

Solarflare™ is a trademark of Advanced Micro Devices, Inc.

Intel®, the Intel logo and Xeon® are trademarks of Intel Corporation or its subsidiaries.

Linux® is the trademark of Linus Torvalds in the U.S. and other countries.

Microsoft®, Windows Server®, and Windows® are trademarks of Microsoft Corporation in the United States, other countries, or both.

IBM®, ibm.com®, and Storwize® are trademarks of IBM in the United States, other countries, or both.

Other company, product, or service names may be trademarks or service marks of others.